



**the
t.bone**

TWS One Vocal
UHF wireless system

Musikhaus Thomann
Thomann GmbH
Hans-Thomann-Straße 1
96138 Burgebrach
Germany
Telephone: +49 (0) 9546 9223-0
E-mail: info@thomann.de
Internet: www.thomann.de

14.01.2016, ID: 312562

Table of contents

1	Safety instructions	4
2	Features and scope of delivery	8
3	Installation and starting up	10
	3.1 General Information.....	10
	3.2 Receiver.....	11
	3.3 Transmitter.....	13
4	Connections and operating elements	14
	4.1 Receiver.....	14
	4.2 Transmitter.....	18
5	Technical specifications	20
	5.1 Receiver.....	20
	5.2 Transmitter.....	21
6	Plug and connection assignment	23
7	Troubleshooting	25
8	Protecting the environment	28

1 Safety instructions

Intended use

This device is intended to be used for the wireless transmission of audio signals from microphones or instruments to amplifiers or active speakers. Use the device only as described in this user manual. Any other use or use under other operating conditions is considered to be improper and may result in personal injury or property damage. No liability will be assumed for damages resulting from improper use.

This device may be used only by persons with sufficient physical, sensorial, and intellectual abilities and having corresponding knowledge and experience. Other persons may use this device only if they are supervised or instructed by a person who is responsible for their safety.

Safety



DANGER!

Danger for children

Ensure that plastic bags, packaging, etc. are disposed of properly and are not within reach of babies and young children. Choking hazard!

Ensure that children do not detach any small parts (e.g. knobs or the like) from the unit. They could swallow the pieces and choke!

Never let children unattended use electrical devices.



NOTICE!

Operating conditions

This device has been designed for indoor use only. To prevent damage, never expose the device to any liquid or moisture. Avoid direct sunlight, heavy dirt, and strong vibrations.



NOTICE!

External power supply

The device is powered by an external power supply. Before connecting the external power supply, ensure that the input voltage (AC outlet) matches the voltage rating of the device and that the AC outlet is protected by a residual current circuit breaker. Failure to do so could result in damage to the device and possibly the user.

Unplug the external power supply before electrical storms occur and when the device is unused for long periods of time to reduce the risk of electric shock or fire.



NOTICE!

Risk of fire due to incorrect polarity

Incorrectly inserted batteries may destroy the device or the batteries.

Ensure that proper polarity is observed when inserting batteries.



NOTICE!

Possible damage by leaking batteries

Leaking batteries can cause permanent damage to the device.

Take batteries out of the device if it is not going to be used for a longer period.

2 Features and scope of delivery

The UHF wireless system TWS One Vocal is particularly suitable for professional audio transmission, for example, at events, on rock stages and in concert halls, theatres, musicals or discotheques.

Your UHF wireless system TWS One Vocal consists of the following components:

- Receiver TWS One R
 - Adjustable volume
 - Fixed antenna
 - Very high sensitivity at very high signal-to-noise ratio
 - Output: 1/4" phone socket (unbalanced)
 - Operating supply voltage: DC 12 V $\overline{\text{---}}$
- Handheld transmitter TWS One HT
 - Dynamic microphone
 - Slide switch to turn the microphone on and off
 - Operating supply voltage: 2 AA cells (LR6, 1.5 V) or corresponding rechargeable batteries

Included accessories: 12 V power adapter, cable with two 1/4" phone plugs for connection to a mixer or amplifier, carrying case

The system can be operated free of charge and registration in Europe. Two systems can be operated simultaneously. The transmission range of the system under normal conditions is approximately 50 metres. The system operates at a fixed frequency according to the following table:

System description	Used frequency (MHz)
TWS One A Vocal (item no. 312562)	863.100 MHz
TWS One B Vocal (item no. 312563)	863.900 MHz
TWS One C Vocal (item no. 312564)	864.500 MHz
TWS One D Vocal (item no. 312566)	864.900 MHz

3 Installation and starting up

3.1 General Information

Unpack and carefully check that there is no transportation damage before using the unit. Keep the equipment packaging. To fully protect the device against vibration, dust and moisture during transportation or storage use the original packaging or your own packaging material suitable for transport or storage, respectively.

Establish all connections as long as the unit is switched off. Use the shortest possible high-quality cables for all connections.

Notes on radio transmission

- This equipment uses a frequency range that is free of charge and registration within the European Union.
For more information, please visit: <http://www.thomann.de>.
- Make sure that no metal objects are located between transmitter and receiver.
- Avoid interference by other radio and in-ear systems.

3.2 Receiver

Connecting the power supply



NOTICE!

External power supply

The device is powered by an external power supply. Before connecting the external power supply, ensure that the input voltage (AC outlet) matches the voltage rating of the device and that the AC outlet is protected by a residual current circuit breaker. Failure to do so could result in damage to the device and possibly the user.

Unplug the external power supply before electrical storms occur and when the device is unused for long periods of time to reduce the risk of electric shock or fire.

First, connect the power adapter to the receiver and then plug the power adapter into the power outlet.

Connecting audio and starting up

Connect the audio output of the receiver to your mixer or your amplifier.

Set the volume control first as follows:

- If you are using a microphone input of your mixer, turn the knob to about 1 o'clock.
- If you are using a line input of your mixer, turn the knob clockwise all the way to the stop.

To get the best sound quality, a fine adjustment of the controller may be required.

3.3 Transmitter

Inserting batteries into the receiver

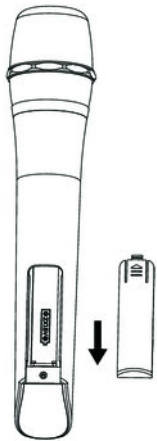

1. ➤ Make sure that the transmitter is turned off, the main switch is in 'OFF' position.
2. ➤ Open the battery compartment cover by pressing on the fastening and sliding it down.
3. ➤ Insert the batteries. Pay attention to the correct location of the poles.
4. ➤ Close the battery compartment and turn on the transmitter. Slide the power switch to the 'ON' position. The LED lights up briefly.
5. ➤ Turn on the transmitter and check the transmission by speaking or singing. If necessary, adjust the level on the receiver, on your mixing console or your amplifier.

4 Connections and operating elements

4.1 Receiver

Front panel

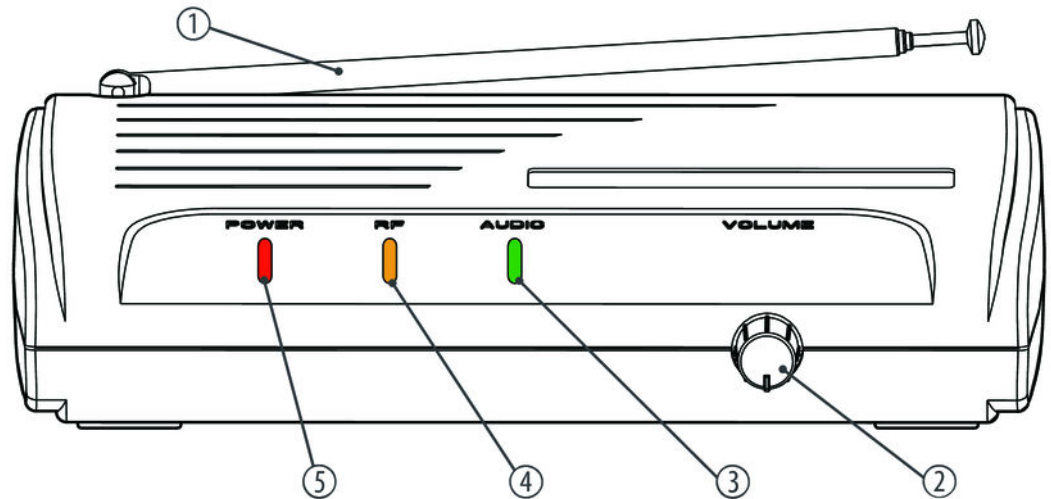

1	Rotatable and swivelling antenna.
2	<i>[VOLUME]</i> Output level control.
3	<i>[AUDIO]</i> The indicator lights green when an audio signal is received.
4	<i>[RF]</i> The LED lights orange when a radio connection to the transmitter is present.
5	<i>[POWER]</i> The LED lights red when the unit is powered on and ready for use.

Rear panel

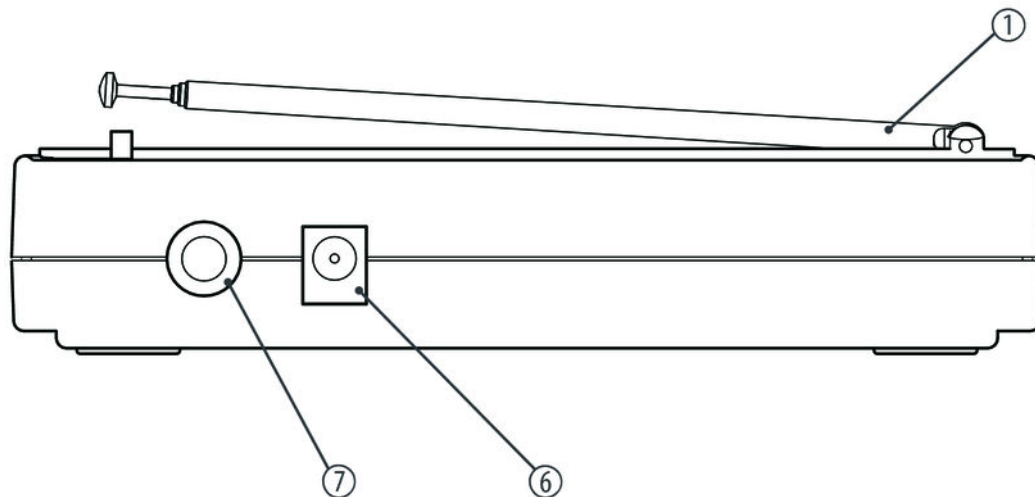

1	Rotatable and swivelling antenna.
6	<i>[DC IN]</i> Socket for connecting the supplied AC adapter. If you are using a different power supply, observe the correct voltage, the polarity of the plug and the power consumption.
7	<i>[AUDIO OUT]</i> 1/4" phone socket as unbalanced audio signal output for direct connection to a mixer, an amplifier or recording device.

4.2 Transmitter

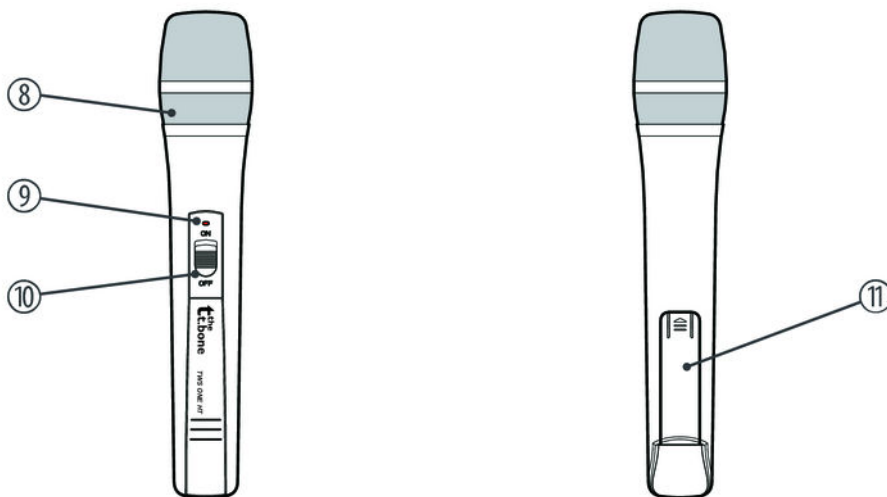

8	Microphone capsule.
9	Indicator LED Displays the state of the batteries. If you turn on the transmitter, the LED lights up briefly, indicating that the batteries still provide sufficient voltage. When the LED lights continuously, the batteries are exhausted. In this case, you should replace the batteries or charge the rechargeable batteries.
10	Main switch. Turns the unit on ('ON') or off ('OFF').
11	Battery compartment for 2 AA cells (LR6, 1.5 V) or appropriate rechargeable batteries. Inside the battery compartment is a sticker with the indication of the frequency range in which the device operates. The indication here must match the information on the bottom of the receiver.

5 Technical specifications

5.1 Receiver

Output	1/4" phone socket (unbalanced)
Output Level (@ a 3 k Ω load)	-18 dBV
Output impedance	1 k Ω
Carrier frequency	UHF band (863...865 MHz)
Modulation type	Frequency modulation (FM)
Transmission range under normal conditions	approx. 50 m
Signal-to-noise ratio	> 92 dB
Side and image frequency rejection	90 dB min.
NF frequency response	60 Hz...16 kHz (\pm 3 dB)
THD	< 1 %

Dynamic range	> 90 dB (A-weighted)
Operating supply voltage	DC 12 V $\overline{\text{---}}$
Dimensions (W × D × H, without antenna)	150 mm × 118 mm × 35 mm
Weight	180 g

5.2 Transmitter

Carrier frequency	UHF band (863...865 MHz)
Modulation type	Frequency modulation (FM)
Transmission power	10 dBm
Maximum audio input level	0 dBV
Operating supply voltage	2 AA cells (LR6, 1.5 V) or corresponding rechargeable batteries
Battery life span	> 8 h

Technical specifications

Dimensions (L × D)	245 mm × 53 mm
Weight (without batteries)	200 g

6 Plug and connection assignment

Introduction

This chapter will help you select the right cables and plugs to connect your valuable equipment in such a way that a perfect sound experience is ensured.

Please note these advices, because especially in 'Sound & Light' caution is indicated: Even if a plug fits into the socket, an incorrect connection may result in a destroyed power amp, a short circuit or 'just' in poor transmission quality!

Balanced and unbalanced transmission

Unbalanced transmission is mainly used in semi-professional environment and in hifi use. Instrument cables with two conductors (one core plus shielding) are typical representatives of the unbalanced transmission. One conductor is ground and shielding while the signal is transmitted through the core.

Unbalanced transmission is susceptible to electromagnetic interference, especially at low levels, such as microphone signals and when using long cables.

In a professional environment, therefore, the balanced transmission is preferred, because this enables an undisturbed transmission of signals over long distances. In addition to the conductors 'Ground' and 'Signal', in a balanced transmission a second core is added. This also transfers the signal, but phase-shifted by 180°.

Since the interference affects both cores equally, by subtracting the phase-shifted signals, the interfering signal is completely neutralized. The result is a pure signal without any noise interference.

1/4" TS phone plug (mono, unbalanced)



1	Signal
2	Ground, shielding

7 Troubleshooting

In the following we list a few common problems that may occur during operation. We give you some suggestions for easy troubleshooting:

Symptom	Remedy
No sound	1. Check the power supply of transmitter and receiver.
	2. Make sure that transmitter and receiver are operating in the same frequency range. The frequency can be found on the devices.
	3. Test the connection between the receiver and the connected audio device (amplifier, mixer). Is the connected audio device turned on and does the signal level at the output of the receiver match the input requirements of the audio device?
	4. See if the audio transmission works when you move the transmitter closer to the receiver.
	5. Make sure that no metal objects near the transmitter or receiver obstruct the transmission.
Transmission is interrupted.	1. Change the orientation of the antenna.
	2. If you use more than one wireless system at the same time, check the used frequencies and channels.
	3. Interference can also be caused by televisions, radios or mobile phones.
The sound is distorted.	Change the <i>[VOLUME]</i> control settings on the receiver.

If the procedures recommended above do not succeed, please contact our Service Center. You can find the contact information at www.thomann.de.

8 Protecting the environment

Disposal of the packaging material



For the transport and protective packaging, environmentally friendly materials have been chosen that can be supplied to normal recycling.

Ensure that plastic bags, packaging, etc. are properly disposed of.

Do not just dispose these materials with your normal household waste, but make sure that they are fed to a recovery. Please follow the notes and markings on the packaging.

Disposal of batteries



Batteries must not be disposed of as domestic waste or thrown into fire. Dispose of the batteries according to national or local regulations regarding hazardous waste. To protect the environment, dispose of empty batteries at your retail store or at appropriate collection sites.

Disposal of your old device



This product is subject to the European Waste Electrical and Electronic Equipment Directive (WEEE). Do not dispose with your normal household waste.

Dispose this device through an approved waste disposal firm or through your local waste facility. When discarding the device, comply with the rules and regulations that apply in your country. If in doubt, consult your local waste disposal facility.



Musikhaus Thomann · Hans-Thomann-Straße 1 · 96138 Burgebrach · Germany · www.thomann.de