



LED Ball BAT 30 RGBW

LED ball

Musikhaus Thomann  
Thomann GmbH  
Hans-Thomann-Straße 1  
96138 Burgebrach  
Germany  
Telephone: +49 (0) 9546 9223-0  
E-mail: [info@thomann.de](mailto:info@thomann.de)  
Internet: [www.thomann.de](http://www.thomann.de)

26.05.2020, ID: 472656

---

# Table of contents

<b>1</b>	<b>General information</b> .....	<b>6</b>
	1.1 Further information.....	7
	1.2 Notational conventions.....	8
	1.3 Symbols and signal words.....	8
<b>2</b>	<b>Safety instructions</b> .....	<b>11</b>
<b>3</b>	<b>Features</b> .....	<b>17</b>
<b>4</b>	<b>Installation</b> .....	<b>19</b>
<b>5</b>	<b>Starting up</b> .....	<b>21</b>
<b>6</b>	<b>Connections and controls</b> .....	<b>23</b>
<b>7</b>	<b>Operating</b> .....	<b>26</b>
	7.1 Starting the device.....	26
	7.2 System settings.....	26
	7.3 Stand-alone mode.....	36
	7.4 DMX operation.....	43
	7.5 Menu overview.....	45

7.6	Functions in 2-channel DMX mode.....	47
7.7	Functions in 3-channel DMX mode.....	47
7.8	Functions in 4-channel DMX mode.....	50
7.9	Functions in 6-channel DMX mode.....	50
7.10	Functions in 9-channel DMX mode.....	52
<b>8</b>	<b>Technical specifications.....</b>	<b>56</b>
<b>9</b>	<b>Plug and connection assignments.....</b>	<b>58</b>
<b>10</b>	<b>Troubleshooting.....</b>	<b>59</b>
<b>11</b>	<b>Cleaning.....</b>	<b>61</b>
<b>12</b>	<b>Protecting the environment.....</b>	<b>62</b>



# 1 General information

This user manual contains important information on the safe operation of the device. Read and follow all safety notes and all instructions. Save this manual for future reference. Make sure that it is available to all persons using this device. If you sell the device to another user, be sure that they also receive this manual.

Our products and user manuals are subject to a process of continuous development. We therefore reserve the right to make changes without notice. Please refer to the latest version of the user manual which is ready for download under [www.thomann.de](http://www.thomann.de).

## 1.1 Further information

On our website ([www.thomann.de](http://www.thomann.de)) you will find lots of further information and details on the following points:

Download	This manual is also available as PDF file for you to download.
Keyword search	Use the search function in the electronic version to find the topics of interest for you quickly.
Online guides	Our online guides provide detailed information on technical basics and terms.
Personal consultation	For personal consultation please contact our technical hotline.
Service	If you have any problems with the device the customer service will gladly assist you.

## 1.2 Notational conventions

This manual uses the following notational conventions:

### Letterings

The letterings for connectors and controls are marked by square brackets and italics.

**Examples:** *[VOLUME]* control, *[Mono]* button.

### Displays



Texts and values displayed on the device are marked by quotation marks and italics.

**Examples:** *'24ch'*, *'OFF'*.

## 1.3 Symbols and signal words

In this section you will find an overview of the meaning of symbols and signal words that are used in this manual.



Signal word	Meaning
<b>DANGER!</b>	This combination of symbol and signal word indicates an immediate dangerous situation that will result in death or serious injury if it is not avoided.
<b>WARNING!</b>	This combination of symbol and signal word indicates a possible dangerous situation that can result in death or serious injury if it is not avoided.
<b>NOTICE!</b>	This combination of symbol and signal word indicates a possible dangerous situation that can result in material and environmental damage if it is not avoided.
Warning signs	Type of danger
	Warning – high-voltage.
	Warning – dangerous optical radiation.

Warning signs	Type of danger
	Warning – danger zone.

## 2 Safety instructions

### Intended use

This device is intended for use as an electronic lighting effect by means of LED technology. The device is designed for professional use and is not suitable for use in households. Use the device only as described in this user manual. Any other use or use under other operating conditions is considered to be improper and may result in personal injury or property damage. No liability will be assumed for damages resulting from improper use.

This device may be used only by persons with sufficient physical, sensorial, and intellectual abilities and having corresponding knowledge and experience. Other persons may use this device only if they are supervised or instructed by a person who is responsible for their safety.

Extend the life of the device by regular breaks in operation and avoid switching it on and off frequently. This device is not suitable for continuous use.

### Safety



#### **DANGER!**

##### **Danger for children**

Ensure that plastic bags, packaging, etc. are disposed of properly and are not within reach of babies and young children. Choking hazard!

Ensure that children do not detach any small parts (e.g. knobs or the like) from the unit. They could swallow the pieces and choke!

Never let children unattended use electrical devices.



#### **DANGER!**

##### **Electric shock caused by high voltages inside**

Within the device there are areas where high voltages may be present. Never remove any covers.

There are no user-serviceable parts inside.

Do not use the device if covers, protectors or optical components are missing or damaged.



**DANGER!**

**Electric shock caused by short-circuit**

Do not modify the mains cable or the plug. Failure to do so could result in electric shock/death or fire. If in doubt, seek advice from a registered electrician.



**WARNING!**

**Eye damage caused by high light intensity**

Never look directly into the light source.



**WARNING!**

**Risk of epileptic shock**

Strobe lighting can trigger seizures in photosensitive epilepsy. Sensitive persons should avoid looking at strobe lights.



### **NOTICE!**

#### **Risk of fire**

Do not block areas of ventilation. Do not install the device near any direct heat source. Keep the device away from naked flames.

**NOTICE!****Operating conditions**

This device has been designed for indoor use only. To prevent damage, never expose the device to any liquid or moisture. Avoid direct sunlight, heavy dirt, and strong vibrations.

Only operate the device within the ambient conditions specified in the chapter 'Technical specifications' of this user manual. Avoid heavy temperature fluctuations and do not switch the device on immediately after it was exposed to temperature fluctuations (for example after transport at low outside temperatures).

Dust and dirt inside can damage the unit. When operated in harmful ambient conditions (dust, smoke, nicotine, fog, etc.), the unit should be maintained by qualified service personnel at regular intervals to prevent overheating and other malfunction.



### **NOTICE!**

#### **Power supply**

Before connecting the device, ensure that the input voltage (AC outlet) matches the voltage rating of the device and that the AC outlet is protected by a residual current circuit breaker. Failure to do so could result in damage to the device and possibly injure the user.

Unplug the device before electrical storms occur and when it is unused for long periods of time to reduce the risk of electric shock or fire.



### **NOTICE!**

#### **Possible damage due to installation of a wrong fuse**

The use of different types of fuses can cause serious damage to the unit. Fire hazard!

Only fuses of the same type may be used.



### 3 Features

LED with extended colour space for strong and brightly glowing accents. Ideal for ambient lighting in clubs, bars and for events

- LED ball made of PVC, diameter: 30 cm
- Ring eyelet M6 as suspension and for securing
- 24 × RGBW LEDs
- Control via DMX (five different modes), included IR remote control and via buttons and display on the unit
- Master / Slave function
- Sound control
- four selectable dimmer curves
- Electronic shutter
- 6 built-in programmes with selectable speed and brightness
- static colour macros with adjustable brightness
- Built-in battery

For technological reasons, the light output of LEDs decreases over their lifetime. This effect increases with higher operating temperature. You can extend the service life of the illuminants by providing adequate ventilation and operating the LEDs with the lowest possible brightness.

## 4 Installation

Unpack and check carefully there is no transportation damage before using the unit. Keep the equipment packaging. To fully protect the product against vibration, dust and moisture during transportation or storage use the original packaging or your own packaging material suitable for transport or storage, respectively.

You can install the device hanging from the ceiling.

### Inserting the battery into the remote control

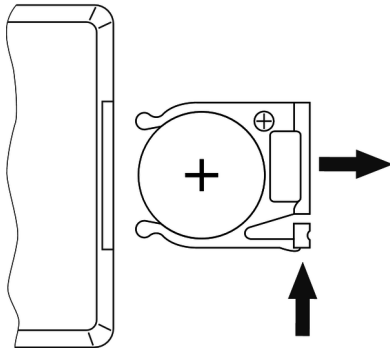

Press the lock of the battery holder to the centre of the housing and pull out the battery holder like a drawer. Insert the battery. The battery is correct if the positive pole points to the housing base of the remote control. Slide the battery holder back into the remote until it clicks into place.

When shipping, the battery is already installed in the remote and protected against discharge by a transparent plastic foil. Remove the plastic foil prior to first use.



*Please note that this device must not be connected to a dimmer.*

## 5 Starting up

Create all connections while the device is off. Use the shortest possible high-quality cables for all connections. Take care when running the cables to prevent tripping hazards.

### Connections in DMX mode

Connect the DMX input of the device to the DMX output of a DMX controller or another DMX device. Connect the output of the first DMX device to the input of the second one, and so on to form a daisy chain. Always ensure that the output of the last DMX device in the daisy chain is terminated with a resistor ( $110\ \Omega$ ,  $\frac{1}{4}\text{ W}$ ).

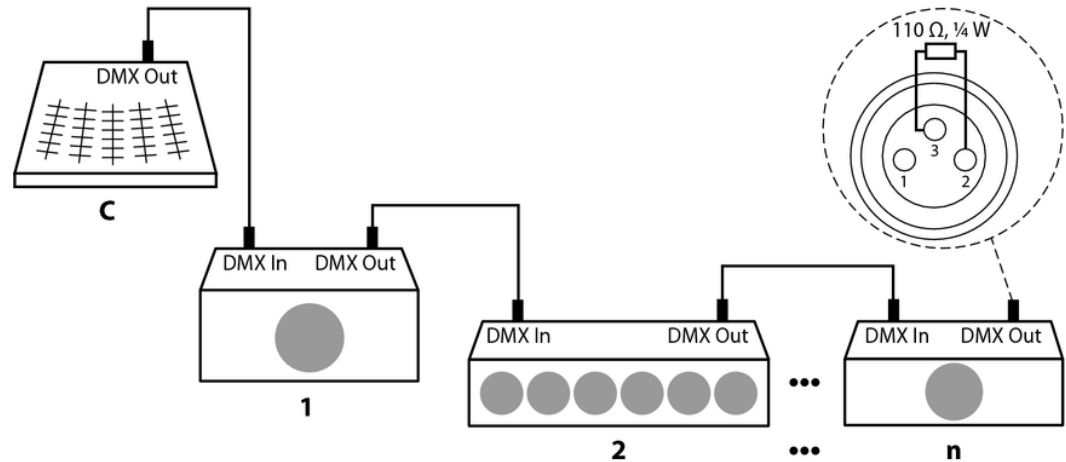

## 6 Connections and controls

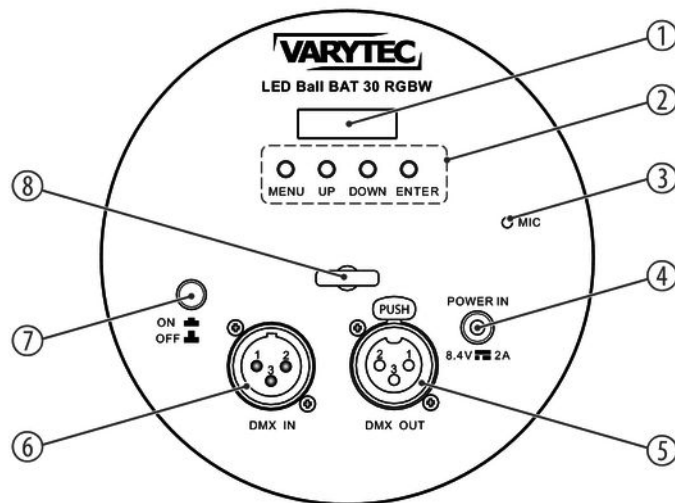

1	Display	
2	Operating buttons	
	<i>[ENTER]</i>	Confirms a selected value.
	<i>[DOWN]</i>	Decreases the displayed value by one.
	<i>[UP]</i>	Increases the displayed value by one.
	<i>[MENU]</i>	Opens the main menu.
3	<i>[MIC]</i>	Built-in microphone for sound control
4	Input socket for external plug-in power supply	
5	<i>[DMX OUT]</i>	DMX output, designed as 3-pin XLR chassis-mounted coupling
6	<i>[DMX IN]</i>	DMX input, designed as 3-pin XLR chassis-mounted plug
7	Pushbutton to turn the device on and off.	
	<i>[ON]</i>	The device is turned on.
	<i>[OFF]</i>	The device is turned off.
8	Ring eyelet M6 as hanging option	



**Remote control**

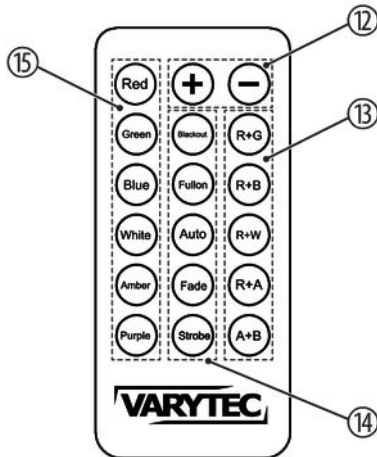

12 *[+], [-]*  
Changes the auto or fade programmes, increases or decreases the strobe speed.

13 Selection of a mixed colour

14 Function selection

*[Blackout]* Button to turn the blackout on or off

*[Strobe]* Turns the Strobe effect (flash) on or off.

*[Fullon]* Turns all colours to full brightness.

*[Auto]* Starts a preprogrammed automatic show.

*[Fade]* Turns the Fade effect (colour transition) on or off.

15 Buttons to select a single basic colour

## 7 Operating

### 7.1 Starting the device

Connect the device to the power supply to start operation.

### 7.2 System settings

#### Activating the main menu

Press *[ENTER]* to activate the main menu. Use *[UP]* or *[DOWN]* to change the respectively indicated value. When the display shows the desired value press *[ENTER]*.

To exit the menu without making changes, press *[MENU]*.

**Timer**

Press *[MENU]* and then *[UP]* or *[DOWN]* until the menu item 'Settings' is displayed and press *[ENTER]*.

Press *[UP]* or *[DOWN]* until the menu item 'Runtime' is displayed and press *[ENTER]*. Use *[UP]* or *[DOWN]* to select one of the following options:

Display	Meaning
'Off'	The timer is turned off.
'4 Hours'	A programme run time of 4 hours is set.
'24 Hours'	A programme run time of 24 hours is set.

Confirm the desired selection with *[ENTER]*.

### Display reversal

Press *[MENU]* and then *[UP]* or *[DOWN]* until the menu item *'Settings'* is displayed and press *[ENTER]*.

Press *[UP]* or *[DOWN]* until the menu item *'Display Reverse'* is displayed and press *[ENTER]*. Use *[UP]* or *[DOWN]* to select one of the following options:

Display	Meaning
'ON'	The display inversion is activated, the display is rotated by 180°.
'OFF'	The display inversion is deactivated.

Confirm the desired selection with *[ENTER]*.

**Backlight of the display**

Press *[MENU]* and then *[UP]* or *[DOWN]* until the menu item '*Settings*' is displayed and press *[ENTER]*.

Press *[UP]* or *[DOWN]* until the menu item '*Display Backlight*' is displayed and press *[ENTER]*. Use *[UP]* or *[DOWN]* to select one of the following options:

Display	Meaning
'ON'	The backlight of the display remains permanently on during operation.
'OFF'	The backlight of the display is switched off 10 seconds after the last setting.

Confirm the desired selection with *[ENTER]*.

### Behaviour on DMX control failure

Press *[MENU]* and then *[UP]* or *[DOWN]* until the menu item *'Settings'* is displayed and press *[ENTER]*.

Press *[UP]* or *[DOWN]* until *'DMX Fail'* is displayed and press *[ENTER]*. Use *[UP]* or *[DOWN]* to select one of the following options:

Display	Meaning
<i>'Hold'</i>	If the DMX control fails, the last setting is retained.
<i>'Blackout'</i>	If the DMX control fails, the spot light is blacked out.
<i>'Emergency Light'</i>	If the DMX control fails, an emergency Light kicks in.

Confirm the desired selection with *[ENTER]*.

**Behaviour on interruption of power supply**

Press *[MENU]* and then *[UP]* or *[DOWN]* until the menu item '*Settings*' is displayed and press *[ENTER]*.

Press *[UP]* or *[DOWN]* until '*AC Failure*' is displayed and press *[ENTER]*. Use *[UP]* or *[DOWN]* to select one of the following options:

<b>Display</b>	<b>Meaning</b>
' <i>No Action</i> '	No action is activated on power supply interruption.
' <i>Blackout</i> '	The spot light is turned off on power supply interruption.
' <i>Emergency Light</i> '	Emergency lighting is switched on on power supply interruption.

Confirm the desired selection with *[ENTER]*.

### Dimmer curve

Press *[MENU]* and then *[UP]* or *[DOWN]* until the menu item 'Settings' is displayed and press *[ENTER]*.

Press *[UP]* or *[DOWN]* until 'Dimmer Curve' is displayed and press *[ENTER]*. Use *[UP]* or *[DOWN]* to select one of the following options:

Display	Meaning
'Linear'	Linear course
'Exponential'	Exponential course
'Logarithmic'	Logarithmic course
'S-curve'	S-curve shaped course

Confirm the desired selection with *[ENTER]*.



## Dimmer settings

Press *[MENU]* and then *[UP]* or *[DOWN]* until the menu item *'Settings'* is displayed and press *[ENTER]*.

Press *[UP]* or *[DOWN]* until *'Dimmer Response'* is displayed and press *[ENTER]*. Use *[UP]* or *[DOWN]* to select one of the following options:

Display	Meaning
<i>'LED'</i>	Dimmer settings for LED are activated.
<i>'Halogen'</i>	Imitation of the dimming behaviour for incandescent light is activated.

Confirm the desired selection with *[ENTER]*.

### Key lock

Press *[MENU]* and then *[UP]* or *[DOWN]* until the menu item 'Settings' is displayed and press *[ENTER]*.

Press *[UP]* or *[DOWN]* until 'Auto Lock' is displayed and press *[ENTER]*. Use *[UP]* or *[DOWN]* to select one of the following options:

Display	Meaning
'On'	The key lock for unintentionally changing the settings is activated.
'Off'	The key lock for unintentionally changing the settings is deactivated.

Confirm the desired selection with *[ENTER]*.

Press *[UP]* and *[DOWN]* for five seconds to release the key lock.

**Remote control**

Press *[MENU]* and then *[UP]* or *[DOWN]* until the menu item 'Settings' is displayed and press *[ENTER]*.

Press *[UP]* or *[DOWN]* until 'IR Remote' is displayed and press *[ENTER]*. Use *[UP]* or *[DOWN]* to select one of the following options:

Display	Meaning
'On'	Control of the device via remote control is activated.
'Off'	Control of the device via remote control is deactivated.

Confirm the desired selection with *[ENTER]*.

**Reset**

Press *[MENU]* and then *[UP]* or *[DOWN]* until the menu item 'Settings' is displayed and press *[ENTER]*.

Press *[UP]* or *[DOWN]* until 'Factory Reset' is displayed and press *[ENTER]*. The display shows 'Reset Now'. Confirm with *[ENTER]*. The device is reset to factory default settings.

### System information

Press *[MENU]* and then *[UP]* or *[DOWN]* until 'System Info' is displayed and press *[ENTER]*. Use *[UP]* or *[DOWN]* to select one of the following options:

Display	Meaning
'Firmware'	The current software version of the device will appear on the display.
'Operation Hours'	The display shows the total number of operating hours.

Confirm the desired selection with *[ENTER]*.

## 7.3 Stand-alone mode

In stand-alone mode, you can make device settings directly by pressing a button.

### Automatic show selection

Press *[MENU]* and then *[UP]* or *[DOWN]* until 'Stand Alone' is displayed and press *[ENTER]*. Press *[UP]* or *[DOWN]* repeatedly, until the display shows 'Auto' and press *[ENTER]*. Use *[UP]* or *[DOWN]* to select one of six automatic shows (display shows 'Program 1' ... 'Program 6') and press *[ENTER]*. To customize the speed and dimmer intensity of the selected show, use *[UP]* or *[DOWN]* to select one of the following options:

Display	Meaning
'Dimmer'	Dimmer intensity
'Speed'	Programme running speed

Use *[UP]* or *[DOWN]* to select a value from '000' to '255' and confirm the value with *[ENTER]*.

### Setting the microphone sensitivity for sound control

Press *[MENU]* and then *[UP]* or *[DOWN]* until 'Stand Alone' is displayed and press *[ENTER]*. Press *[UP]* or *[DOWN]* repeatedly, until the display shows 'Sound' and press *[ENTER]*. Use *[UP]* or *[DOWN]* to select either '000' (microphone off) or a sensitivity in the range of '01' (low) ... '99' (high) and confirm the value with *[ENTER]*.

### Selecting and setting a colour macro

Press *[MENU]* and then *[UP]* or *[DOWN]* until 'Stand Alone' is displayed and press *[ENTER]*. Press *[UP]* or *[DOWN]* repeatedly, until the display shows 'Color Macro' and press *[ENTER]*. Use *[UP]* or *[DOWN]* to select one of the following options:

Display	Meaning
'Color Off'	Colour is turned off
'Red'	Red
'Amber'	Amber
'Yellow warm'	Warm yellow
'Yellow'	Yellow
'Green'	Green
'Turquoise'	Turquoise
'Cyan'	Cobalt blue
'Blue'	Blue
'Lavender'	Lilac

<b>Display</b>	<b>Meaning</b>
'Mauve'	Purple
'Magenta'	Crimson red
'Pink'	Pink
'Warm White'	Warm white
'White'	White
'Cold White'	Cold white

Confirm the desired selection with *[ENTER]*. To set the intensity of the colour macros, select for the respective colour *[UP]* or *[DOWN]* a value from '006' to '255' for the intensity and confirm the value with *[ENTER]*.

The values '000' to '005' are assigned to the 'Color Off' function.

### Selecting and setting a constant colour

Press *[MENU]* and then *[UP]* or *[DOWN]* until 'Stand Alone' is displayed and press *[ENTER]*. Press *[UP]* or *[DOWN]* repeatedly, until the display shows 'Static' and press *[ENTER]*. Use *[UP]* or *[DOWN]* to select one of the following options:

Display	Meaning
'Dimmer'	Dimmer intensity
'Strobe'	Strobe effect
'Red'	Red
'Green'	Green
'Blue'	Blue
'White'	White

Confirm the desired selection with *[ENTER]*. To set the intensity of the dimmer, the frequency of the strobe effect or the intensity of the constant colour, use *[UP]* or *[DOWN]* to select a value in the respective option from '000' to '255' and confirm the value with *[ENTER]*.



**Selecting and setting white light** Press *[MENU]* and then *[UP]* or *[DOWN]* until 'Stand Alone' is displayed and press *[ENTER]*. Press *[UP]* or *[DOWN]* repeatedly, until the display shows 'Tunable White' and press *[ENTER]*. Use *[UP]* or *[DOWN]* to select one of the following options:

Display	Meaning
'Dimmer'	Dimmer intensity
'CTC'	Colour temperature

Confirm the desired selection with *[ENTER]*. To set the intensity of the dimmer, select a value from '000' to '255' in the 'Dimmer' option with *[UP]* or *[DOWN]* and confirm the value with *[ENTER]*. To set the colour temperature, select a colour temperature from '2800 K' (warm white) to '8000 K' (cold white) in the 'CTC' option.

### Setting an individual mixed colour

Press *[MENU]* and then *[UP]* or *[DOWN]* until 'Stand Alone' is displayed and press *[ENTER]*. Press *[UP]* or *[DOWN]* repeatedly, until the display shows 'User Color' and press *[ENTER]*. Use *[UP]* or *[DOWN]* to select one of eight mixed colours (display shows 'Color1...Color8') that you can adjust individually and press *[ENTER]*. To customize the desired mixed colour, use *[UP]* or *[DOWN]* to select one of the following options:

Display	Meaning
'Dimmer'	Dimmer intensity
'Strobe'	Strobe effect
'Red'	Red
'Green'	Green
'Blue'	Blue
'White'	White

Confirm the desired selection with *[ENTER]*. To set the intensity of the dimmer, the frequency of the strobe effect or the intensity of the colour, use *[UP]* or *[DOWN]* to select a value from '000' to '255' and confirm the value with *[ENTER]*.

## 7.4 DMX operation

### Setting the DMX address

Press *[MENU]* and then *[UP]* or *[DOWN]* until the display shows the menu item 'DMX Address'.

Now you can set the number of the first DMX channel to be used by the device (DMX address). Use *[UP]* or *[DOWN]* to select a value between 1 and 512 (the display shows '001' ... '512'). Confirm the selection with *[ENTER]*.

Make sure that this number matches the configuration of your DMX controller. The following table shows the highest possible DMX address for the various DMX modes.

Mode	Highest possible DMX address
2-channel	511
3-channel	510
4-channel	509
6-channel	507
9-channel	504

### Selecting the DMX mode.

Press *[MENU]* and then *[UP]* or *[DOWN]* until the display shows 'DMX Mode'.

With *[UP]* or *[DOWN]* you can now select one of the following DMX modes:

- '2CH' (two channels)
- '3CH' (three channels)
- '4CH' (four channels)
- '6CH' (six channels)
- '9CH' (nine channels)

Confirm the desired selection with *[ENTER]*.

This setting is only relevant when the device is controlled via DMX.

### 7.5 Menu overview

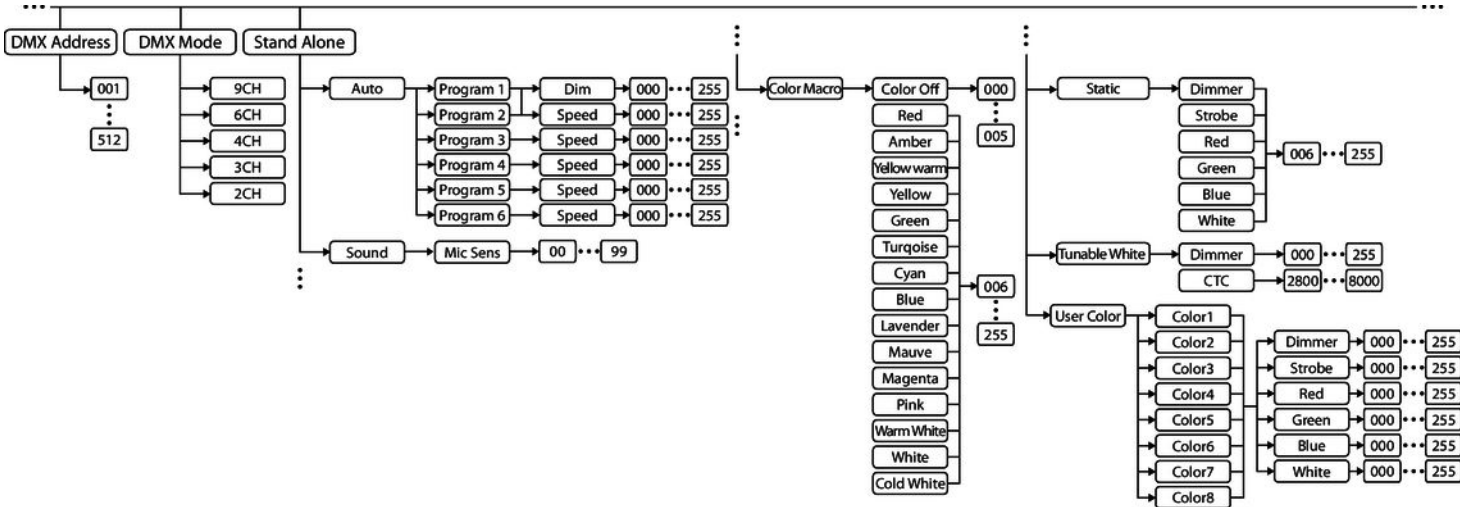

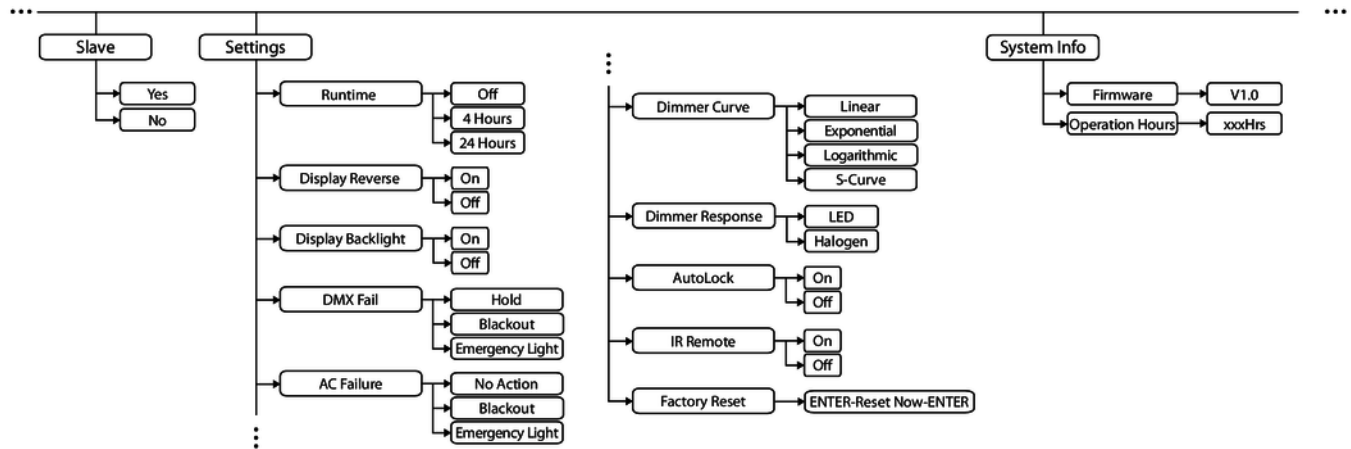

## 7.6 Functions in 2-channel DMX mode

Channel	Value	Function
1	000...255	Dimmer function (0 %...100 %)
2	000...255	White light (7200 K...3200 K with open dimmer)

## 7.7 Functions in 3-channel DMX mode

Channel	Value	Function
1	000...255	Dimmer function (0 %...100 %)
2	000...005	No function
	006...010	Strobe effect off
	011...033	Strobe effect, pulsing, increasing speed
	034...056	Ramp-up strobe effect, random, increasing speed

Channel	Value	Function
	057...079	Ramp-down strobe effect, random, decreasing speed
	080...102	Strobe effect, random, increasing speed
	103...127	Strobe effect, intermittent (5 s...1 s, short burst with break)
	128...250	Strobe effect with increasing frequency (1 Hz to 20 Hz)
	251...255	No strobe effect
3	000...005	Colour is turned off
	006...013	Red
	014...021	Amber
	022...029	Warm yellow
	030...037	Yellow
	038...045	Green
	046...053	Turquoise
	054...061	Cobalt blue



Channel	Value	Function
	062...069	Blue
	070...077	Lilac
	078...085	Purple
	086...093	Crimson red
	094...101	Pink
	102...109	Warm white
	110...117	White
	118...125	Cold white
	126...127	Colour change stop
	128...191	Colour change, increasing speed, colours 1 to 12
	192...255	Colour-fade effect, increasing speed, colours 1 to 12

## 7.8 Functions in 4-channel DMX mode

Channel	Value	Function
1	0...255	Intensity red (0 % to 100 %)
2	0...255	Intensity green (0 % to 100 %)
3	0...255	Intensity blue (0 % to 100 %)
4	0...255	Intensity white (0 % to 100 %)

## 7.9 Functions in 6-channel DMX mode

Channel	Value	Function
1	0...255	Dimmer function (0 % bis 100 %)
2	000...005	No function
	006...010	Strobe effect off

Channel	Value	Function
	011...033	Strobe effect, pulsing, increasing speed
	034...056	Ramp-up strobe effect, random, increasing speed
	057...079	Ramp-down strobe effect, random, decreasing speed
	080...102	Strobe effect, random, increasing speed
	103...127	Strobe effect, intermittent (5 s...1 s, short burst with break)
	128...250	Strobe effect with increasing frequency (1 Hz to 20 Hz)
	251...255	No strobe effect
3	000...255	Intensity red (0 % to 100 %)
4	000...255	Intensity green (0 % to 100 %)
5	000...255	Intensity blue (0 % to 100 %)
6	000...255	Intensity white (0 % to 100 %)

## 7.10 Functions in 9-channel DMX mode

Channel	Value	Function
1	000...255	Dimmer function (0 % bis 100 %)
2	000...005	No function
	006...010	Strobe effect off
	011...033	Strobe effect, pulsing, increasing speed
	034...056	Ramp-up strobe effect, random, increasing speed
	057...079	Ramp-down strobe effect, random, decreasing speed
	080...102	Strobe effect, random, increasing speed
	103...127	Strobe effect, intermittent (5 s...1 s, short burst with break)
	128...250	Strobe effect with increasing frequency (1 Hz to 20 Hz)
	251...255	No strobe effect
3	000...255	Intensity red (0 % to 100 %)

Channel	Value	Function
4	000...255	Intensity green (0 % to 100 %)
5	000...255	Intensity blue (0 % to 100 %)
6	000...255	Intensity white (0 % to 100 %)
7	000...005	Colour is turned off
	006...013	Red
	014...021	Amber
	022...029	Warm yellow
	030...037	Yellow
	038...045	Green
	046...053	Turquoise
	054...061	Cobalt blue
	062...069	Blue
	070...077	Lilac

Channel	Value	Function
	078...085	Purple
	086...093	Crimson red
	094...101	Pink
	102...109	Warm white
	110...117	White
	118...125	Cold white
	126...127	Colour change stop
	128...191	Colour change, increasing speed, colours 1 to 12
	192...255	Colour-fade effect, increasing speed, colours 1 to 12
8	000...005	Colour temperature off (with RGBW and colour macros)
	006...255	Colour temperature of 7200 K to 3200 K
9	000...005	No function
	006...063	Dimmer curve, linear

---

Channel	Value	Function
	064...127	Dimmer curve, exponential
	128...191	Dimmer curve, logarithmic
	200...255	Dimmer curve, S-shaped

## 8 Technical specifications

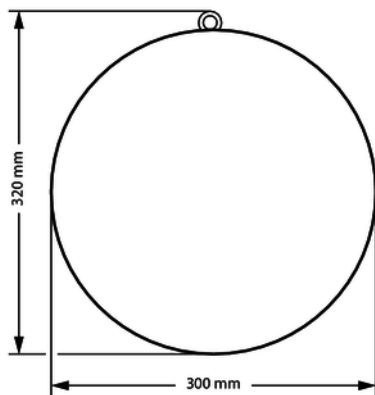

Light source	24 × 4in1 RGBW LED, SMD5050	
Control	DMX	
	IR remote control	
	Buttons and display on the unit	
Number of DMX channels	2, 3, 4, 6, 9	
Input connections	Voltage supply	Input socket for external plug-in power supply
	DMX control	XLR chassis socket, 3-pin
Output connections	DMX control	XLR chassis socket, 3-pin
Power consumption	max. 5 W	
Voltage supply	Plug-in power supply (8.4 V $\overline{\text{---}}$ / 2 A , centre positive)	
Battery / rechargeable battery	Battery type	Lithium-ion



	Voltage	3.7 V
	Capacity	4000 mAh
Battery for the remote control	Battery type	Lithium button cell, 3 V, CR 2025
Protection class	IP20	
Mounting options	hanging	
Dimensions (W × H × D)	300 mm × 300 mm × 320 mm	
Weight	1.1 kg	
Ambient conditions	Temperature range	0 °C...40 °C
	Relative humidity	50 %, non-condensing

### Further information

Type	Ball
Rechargeable battery operation	Yes

## 9 Plug and connection assignments

### Introduction

This chapter will help you select the right cables and plugs to connect your valuable equipment so that a perfect light experience is guaranteed.

Please take our tips, because especially in 'Sound & Light' caution is indicated: Even if a plug fits into a socket, the result of an incorrect connection may be a destroyed DMX controller, a short circuit or 'just' a not working light show!

### DMX connections

The unit offers a 3-pin XLR socket for DMX output and a 3-pin XLR plug for DMX input. Please refer to the drawing and table below for the pin assignment of a suitable XLR plug.



Pin	Configuration
1	Ground, shielding
2	Signal inverted (DMX-, 'cold signal')
3	Signal (DMX+, 'hot signal')

## 10 Troubleshooting



### **NOTICE!**

#### **Possible data transmission errors**

For error-free operation make use of dedicated DMX cables and do not use ordinary microphone cables.

Never connect the DMX input or output to audio devices such as mixers or amplifiers.

In the following we list a few common problems that may occur during operation. We give you some suggestions for easy troubleshooting:

Symptom	Remedy
The unit does not work, no light	Check the mains connection and the main fuse.
Apparently no function despite proper power supply	Check if the unit is in DMX mode or in 'slave' mode. If so, check the unit in another mode.
No response to the DMX controller	1. Check the address settings and the DMX polarity. 2. Try using another DMX controller. 3. Check whether the DMX cables run near or parallel to high-voltage cables that may cause damage or interference to a DMX interface circuit.

If the procedures recommended above do not succeed, please contact our Service Center. You can find the contact information at [www.thomann.de](http://www.thomann.de).

# 11 Cleaning

## Optical lenses

Clean the optical lenses, that are accessible from the outside, regularly in order to optimize the light output. The frequency of cleaning depends on the operating environment: wet, smoky or particularly dirty surroundings can cause more accumulation of dirt on the optics of the device.

- Clean with a soft cloth using our lamp and lens cleaner (item no. 280122).
- Always dry the parts carefully.

## Fan grids

The fan grids of the device must be cleaned of any contamination, such as dust, etc. on a regular basis. Before cleaning, switch off the device and disconnect mains-operated devices from the mains. Only use pH-neutral, solvent-free and non-abrasive cleaning agents. Clean the unit with a slightly damp lint-free cloth.

## 12 Protecting the environment

### Disposal of the packaging material



For the transport and protective packaging, environmentally friendly materials have been chosen that can be supplied to normal recycling.

Ensure that plastic bags, packaging, etc. are properly disposed of.

Do not just dispose these materials with your normal household waste, but make sure that they are fed to a recovery. Please follow the notes and markings on the packaging.

### Disposal of batteries



Batteries must not be disposed of as domestic waste or thrown into fire. Dispose of the batteries according to national or local regulations regarding hazardous waste. To protect the environment, dispose of empty batteries at your retail store or at appropriate collection sites.

### Disposal of your old device



This product is subject to the European Waste Electrical and Electronic Equipment Directive (WEEE) in its currently valid version. Do not dispose with your normal household waste.

Dispose this device through an approved waste disposal firm or through your local waste facility. When discarding the device, comply with the rules and regulations that apply in your country. If in doubt, consult your local waste disposal facility.











