



Battery Event Par  
IP65 6in1

LED spotlight

Musikhaus Thomann  
Thomann GmbH  
Hans-Thomann-Straße 1  
96138 Burgebrach  
Germany  
Telephone: +49 (0) 9546 9223-0  
E-mail: [info@thomann.de](mailto:info@thomann.de)  
Internet: [www.thomann.de](http://www.thomann.de)

06.06.2019, ID: 435529 (V3)

---

# Table of contents

<b>1</b>	<b>General information</b> .....	<b>6</b>
	1.1 Further information.....	7
	1.2 Notational conventions.....	8
	1.3 Symbols and signal words.....	8
<b>2</b>	<b>Safety instructions</b> .....	<b>11</b>
<b>3</b>	<b>Features</b> .....	<b>16</b>
<b>4</b>	<b>Installation</b> .....	<b>18</b>
	4.1 Dealing with lithium batteries.....	23
<b>5</b>	<b>Starting up</b> .....	<b>25</b>
<b>6</b>	<b>Connections and controls</b> .....	<b>28</b>
<b>7</b>	<b>Operating</b> .....	<b>34</b>
	7.1 Starting the device.....	34
	7.2 Main menu.....	34
	7.3 Enabling and disabling of the wireless DMX connection.....	38
	7.4 Functions in 3-channel DMX mode.....	39

7.5	Functions in 4-channel DMX mode.....	39
7.6	Functions in 6-channel DMX mode.....	40
7.7	Functions in 9-channel DMX mode.....	41
7.8	Functions in 11-channel DMX mode.....	43
7.9	Menu overview.....	45
<b>8</b>	<b>Technical specifications.....</b>	<b>46</b>
<b>9</b>	<b>Plug and connection assignments.....</b>	<b>49</b>
<b>10</b>	<b>Troubleshooting.....</b>	<b>50</b>
<b>11</b>	<b>Cleaning.....</b>	<b>52</b>
<b>12</b>	<b>Protecting the environment.....</b>	<b>53</b>



Battery Event Par IP65 6in1  
LED spotlight

# 1 General information

This user manual contains important information on the safe operation of the device. Read and follow all safety notes and all instructions. Save this manual for future reference. Make sure that it is available to all persons using this device. If you sell the device to another user, be sure that they also receive this manual.

Our products and user manuals are subject to a process of continuous development. We therefore reserve the right to make changes without notice. Please refer to the latest version of the user manual which is ready for download under [www.thomann.de](http://www.thomann.de).

## 1.1 Further information

On our website ([www.thomann.de](http://www.thomann.de)) you will find lots of further information and details on the following points:

Download	This manual is also available as PDF file for you to download.
Keyword search	Use the search function in the electronic version to find the topics of interest for you quickly.
Online guides	Our online guides provide detailed information on technical basics and terms.
Personal consultation	For personal consultation please contact our technical hotline.
Service	If you have any problems with the device the customer service will gladly assist you.

## 1.2 Notational conventions

This manual uses the following notational conventions:

### Letterings

The letterings for connectors and controls are marked by square brackets and italics.

**Examples:** *[VOLUME]* control, *[Mono]* button.

### Displays



Texts and values displayed on the device are marked by quotation marks and italics.



**Examples:** *'24ch'*, *'OFF'*.

## 1.3 Symbols and signal words

In this section you will find an overview of the meaning of symbols and signal words that are used in this manual.



Signal word	Meaning
<b>DANGER!</b>	This combination of symbol and signal word indicates an immediate dangerous situation that will result in death or serious injury if it is not avoided.
<b>WARNING!</b>	This combination of symbol and signal word indicates a possible dangerous situation that can result in death or serious injury if it is not avoided.
<b>NOTICE!</b>	This combination of symbol and signal word indicates a possible dangerous situation that can result in material and environmental damage if it is not avoided.
Warning signs	Type of danger
	Warning – high-voltage.
	Warning – dangerous optical radiation.

Warning signs	Type of danger
 A yellow triangular warning sign with a black border. Inside the triangle, there is a black silhouette of a crane hook lifting a rectangular load.	Warning – suspended load.
 A yellow triangular warning sign with a black border. Inside the triangle, there is a large black exclamation mark.	Warning – danger zone.

## 2 Safety instructions

### Intended use

This device is intended for use as an electronic lighting effect by means of LED technology. The device is designed for professional use and is not suitable for use in households. Use the device only as described in this user manual. Any other use or use under other operating conditions is considered to be improper and may result in personal injury or property damage. No liability will be assumed for damages resulting from improper use.

This device may be used only by persons with sufficient physical, sensorial, and intellectual abilities and having corresponding knowledge and experience. Other persons may use this device only if they are supervised or instructed by a person who is responsible for their safety.

Extend the life of the device by regular breaks in operation and avoid switching it on and off frequently. This device is not suitable for continuous use.

### Safety



#### **DANGER!**

##### **Danger for children**

Ensure that plastic bags, packaging, etc. are disposed of properly and are not within reach of babies and young children. Choking hazard!

Ensure that children do not detach any small parts (e.g. knobs or the like) from the unit. They could swallow the pieces and choke!

Never let children unattended use electrical devices.



#### **DANGER!**

##### **Electric shock caused by short-circuit**

Do not modify the mains cable or the plug. Failure to do so could result in electric shock/death or fire. If in doubt, seek advice from a registered electrician.



**DANGER!**

**Electric shock caused by high voltages inside**

Within the device there are areas where high voltages may be present. Never remove any covers.

There are no user-serviceable parts inside.

Do not use the device if covers, protectors or optical components are missing or damaged.



**WARNING!**

**Eye damage caused by high light intensity**

Never look directly into the light source.



**WARNING!**

**Risk of epileptic shock**

Strobe lighting can trigger seizures in photosensitive epilepsy. Sensitive persons should avoid looking at strobe lights.



**NOTICE!**

**Risk of fire**

Do not block areas of ventilation. Do not install the device near any direct heat source. Keep the device away from naked flames.



**NOTICE!**

**Power supply**

Before connecting the device, ensure that the input voltage (AC outlet) matches the voltage rating of the device and that the AC outlet is protected by a residual current circuit breaker. Failure to do so could result in damage to the device and possibly injure the user.

Unplug the device before electrical storms occur and when it is unused for long periods of time to reduce the risk of electric shock or fire.

### 3 Features

Due to its sturdy and weather-proof housing made of die-cast aluminium, the battery-powered LED spotlight is especially suitable for outdoor use. With the very bright six-colour LEDs, it is particularly suitable for professional lighting tasks.

Special features of the device:

- 6 × 6in1 LEDs (RGBWAUV, each 15 W)
- Control via DMX, Wireless DMX, the supplied IR remote control and via buttons and display on the unit
- Built-in automatic show programmes
- Master / Slave operation
- Sound control
- Protection class IP65
- Sturdy double bracket for secure attachment to trusses or firm footing on the ground
- Connectors for power supply and DMX control via splashproof lockable plugs and couplings
- Mains power adapter with safety plug included



- Rugged die-cast aluminium housing
- Pressure equalisation element (prevents the development of condensation inside the device)

### **Information about protection class IP65**

Equipment with protection class IP65 are dust-tight and completely protected against contact (first code number). They are also protected against splash water from any angle (second code digit). That is why this equipment can also be used outdoors. Event technology equipment is generally only designed for temporary use however (event lighting) and not for permanent use outdoors.

The specified protection class does not make a statement about the weather resistance of the equipment (resistance to changing ambient conditions as well as against the effects of sunlight and UV rays).

The seals and screw connections of the equipment must be checked regularly to ensure a fault-free operation. In cases of doubt, consult a specialist workshop in due time.

For technological reasons, the light output of LEDs decreases over their lifetime. This effect increases with higher operating temperature. You can extend the service life of the illuminants by providing adequate ventilation and operating the LEDs with the lowest possible brightness.

## 4 Installation

Unpack and check carefully there is no transportation damage before using the unit. Keep the equipment packaging. To fully protect the product against vibration, dust and moisture during transportation or storage use the original packaging or your own packaging material suitable for transport or storage, respectively.



**WARNING!**

**Risk of injury caused by falling objects**

Make sure that the installation complies with the standards and rules that apply in your country. Always secure the device with a secondary safety attachment, such as a safety cable or a safety chain.



**NOTICE!**

**Risk of overheating**

Always ensure sufficient ventilation.

The ambient temperature must not exceed the limits stated in the chapter Technical Specifications of the User Manual.



**NOTICE!**

**Use of stands**

When mounting the device onto a stand, ensure that the stand is in a safe and stable position and that the weight of the device does not exceed the maximum permissible load capacity of the stand.



### **NOTICE!**

#### **Possible data transmission errors**

For error-free operation make use of dedicated DMX cables and do not use ordinary microphone cables.

Never connect the DMX input or output to audio devices such as mixers or amplifiers.



### **NOTICE!**

#### **Possible damage due to moisture**

Moisture entering into open connectors (plugs and couplers) of DMX or power cords can cause short circuits.

Close unused connectors with end caps intended for this purpose ([www.thomann.de](http://www.thomann.de)).

## Mounting options

You can install the unit in hanging or standing position. When in use, the device must always be attached to a solid surface or an approved truss. Use the openings provided on the two-piece bracket for attaching.

Always work from a stable platform whenever installing, moving or servicing the unit. In doing so, the area underneath the unit must be cordoned off.

The safety cable must be attached to the bracket.



*Please note that this device must not be connected to a dimmer.*

### Inserting the battery into the remote control

Press the lock of the battery holder to the centre of the housing and pull out the battery holder like a drawer. Insert the battery. The battery is correct if the positive pole points to the housing base of the remote control. Slide the battery holder back into the remote until it clicks into place.

When shipping, the battery is already installed in the remote and protected against discharge by a transparent plastic foil. Remove the plastic foil prior to first use.

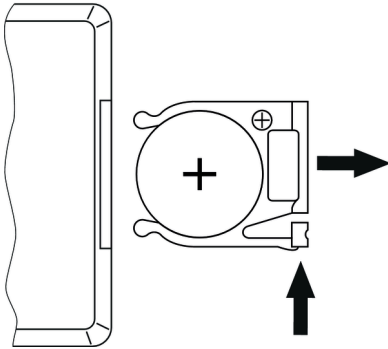

## 4.1 Dealing with lithium batteries



### **WARNING!**

#### **Incorrect handling of lithium batteries can result in injury**

In the event of a short circuit, overheating or mechanical damage, lithium batteries can cause severe injuries.

Follow the advice on the correct handling of lithium batteries in the present section.

When handled correctly and appropriately lithium batteries pose no risk.

Store lithium batteries in a cool, dry place, ideally in the original packaging.

Store lithium batteries away from heat sources (e.g. radiators or sunlight). Lithium batteries are hermetically sealed. Never attempt to open a lithium battery.

If the battery housing is damaged small amounts of the electrolyte may leak out. If this should happen, seal the lithium battery in airtight packaging and wipe up the traces of electrolyte using absorbent paper towels. You must wear protective rubber gloves when doing so. Clean your hands and the affected surface thoroughly with cold water.

Never attempt to recharge non-rechargeable lithium batteries. When charging lithium batteries you must use a suitable charging device intended for the purpose.

Before disposing of the device remove the lithium batteries. Protect used lithium batteries against potential short circuits, e.g. by covering the poles with adhesive tape.

Only use powder extinguishers or other suitable extinguishing agents to extinguish a burning lithium battery.



## 5 Starting up

Create all connections while the device is off. Use the shortest possible high-quality cables for all connections. Take care when running the cables to prevent tripping hazards.

### Connections in DMX mode

Connect the DMX input of the device to the DMX output of a DMX controller or another DMX device. Connect the output of the first DMX device to the input of the second one, and so on to form a daisy chain. Always ensure that the output of the last DMX device in the daisy chain is terminated with a resistor ( $110\ \Omega$ ,  $\frac{1}{4}\text{ W}$ ).

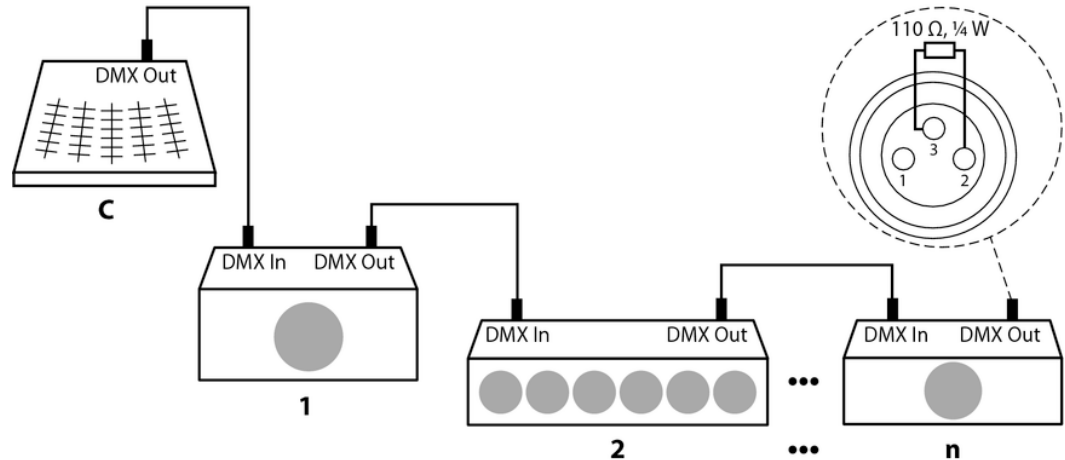

**Connections in master/slave mode**

When you configure a group of devices in master/slave mode, the first unit will control the other units for an automatic, sound-activated, synchronized show. This function is ideal when you want to start a show immediately. Connect the DMX output of the master device to the DMX input of the first slave device. Then connect the DMX output of the first slave device to the DMX input of the second slave device and so on.

## 6 Connections and controls

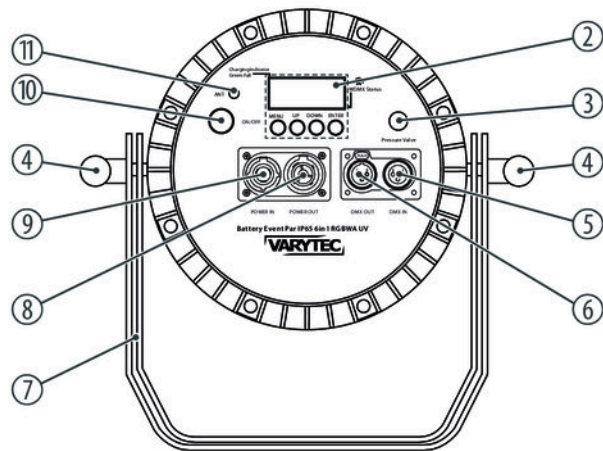
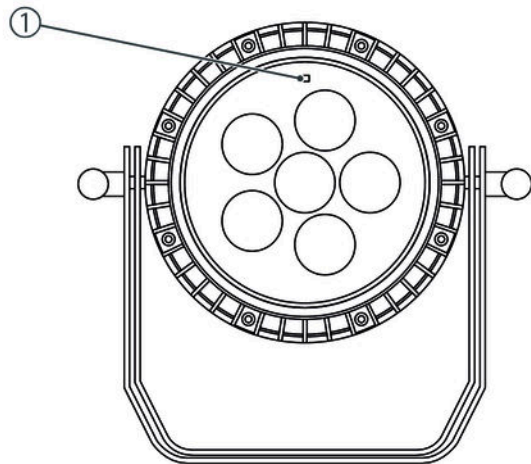

1	Infrared sensor for the remote control signals
2	<p>Display and keypad</p> <p>The LED in the upper left corner of the display lights up red when the built-in battery is charging and green when it is fully charged.</p> <p><i>[MENU]</i></p> <p>Activates the main menu and toggles between menu items.</p> <p><i>[UP]</i></p> <p>Increments the displayed value by 1</p> <p><i>[DOWN]</i></p> <p>Decrements the displayed value by 1</p> <p><i>[ENTER]</i></p> <p>Chooses between the options of the selected mode</p> <p>The LED in the lower right corner of the display indicates that a wireless DMX signal is received.</p>
3	<p><i>[Pressure Valve]</i></p> <p>Pressure compensation element</p>

4	Locking screws for the brackets.
5	<i>[DMX IN]</i> DMX input.
6	<i>[DMX OUT]</i> DMX output
7	Two-piece bracket for hanging or installation and for securing the safety cable
8	<i>[POWER OUT]</i> Lockable output socket (Power Twist IP65) for the power supply of further units
9	<i>[POWER IN]</i> Lockable input socket (Power Twist IP65) for power supply.
10	<i>[ON/OFF]</i> Main switch. Turns the device on and off
11	<i>[ANT]</i> Antenna for the signal of a wireless DMX system

**Remote control**

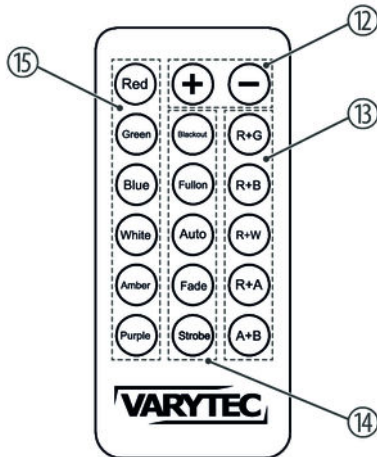

12	[+], [-]	Changes auto programmes and fade programmes, increases or decreases strobe speed
13		Selection of a mixed colour

14 Function selection

*[Blackout]*

Button to turn the blackout on or off

*[Strobe]*

Turns the Strobe effect (flash) on or off

*[Fullon]*

Turns all colours to full brightness

*[Auto]*

Starts a preprogrammed automatic show

*[Fade]*

Turns the Fade effect (colour transition) on or off

15 Buttons for selecting a primary colour





*The IR remote control only works when the receiver at the unit is enabled via the menu.*

## 7 Operating

### 7.1 Starting the device

Reconnect the device to the mains if needed. Switch the unit on with the main switch to start operation. After a few seconds, the display indicates that a reset is in progress. The device is then ready for use. The display shows the operating mode that was selected when the unit was last powered off.

### 7.2 Main menu

Press *[ENTER]* to activate the main menu. Use *[UP]* or *[DOWN]* to select a submenu. When the display shows the desired submenu press *[ENTER]* to open it up. To close the main menu, press *[MODE]*.

The following table shows the setting options.

Main menu	Menu level 2	Menu level 3	Menu level 4	
Meaning				
'Addr'	'A001' ... 'A512'	Setting the DMX address		
'Chnd'	Selecting a DMX mode			
	'Ch 3'	3-channel DMX mode		
	'Ch 4'	4-channel DMX mode		
	'Ch 6'	6-channel DMX mode		
	'Ch 9'	9-channel DMX mode		
	'Ch11'	11-channel DMX mode		
'Nanu'	Static colour			
	'red'	'0' ... '255'	Amount red (0 % to 100 %)	
	'gree'	'0' ... '255'	Amount green (0 % to 100 %)	
	'bLUe'	'0' ... '255'	Amount blue (0 % to 100 %)	
	'Uhte'	'0' ... '255'	Amount white (0 % to 100 %)	

Main menu	Menu level 2	Menu level 3	Menu level 4
	<b>Meaning</b>		
	'yeLL'	'0' ... '255'	Amount amber (0 % to 100 %)
	'Uu'	'0' ... '255'	Amount UV (0 % to 100 %)
'CoLo'	'Co 1' ... 'Co 32'	Selecting a pre-defined colour	
'Auto'	Preprogrammed automatic show		
	'SH-1' ... 'SH-5'	Selecting a show	
	'SP01' ... 'SP15'	Running speed	
'Fade'	Colour change with fade effect		
	'Fa01' ... 'Fa15'	Selecting a fade effect	
	'SP01' ... 'SP15'	Programme speed of the fade effect	
'SoUn'	Sound control		
	'So00' ... 'So10'	Microphone sensitivity for the sound control	
'FLSH'	Strobe effect		

Main menu	Menu level 2	Menu level 3	Menu level 4	
Meaning				
	'FL00' ... 'FL15'	Speed of the strobe effect		
'SLAU'	Operating mode			
	'SL-N'	Operating mode 'Master'		
	'SL-U'	Operating mode 'Slave'		
'Ulr'	Receiver for Wireless DMX			
	'oN'	Enabled		
	'oFF'	Disabled		
'Batt'	Indicates the battery charging state			
	'000' ... '100'	In percent		
'lr'	Infrared sensor for the remote control signals			
	'oN'	Enabled		
	'oFF'	Disabled		

## 7.3 Enabling and disabling of the wireless DMX connection

1. ▶ Open the menu '*Ulr*' and select the item '*On*'.
2. ▶ Switch your wireless solution transmitter on and press the connection button on the transmitter.
  - ⇒ The LED in the lower right corner of the display indicates with flashing that a connection is establishing.
3. ▶ Open the menu '*Ulr*' and select the item '*oFF*' to disable an existing wireless DMX connection.
  - ⇒ The LED in the lower right corner of the display goes out.

## 7.4 Functions in 3-channel DMX mode

Channel	Value	Function
1	0...255	Intensity red (0 % to 100 %)
2	0...255	Intensity green (0 % to 100 %)
3	0...255	Intensity blue (0 % to 100 %)

## 7.5 Functions in 4-channel DMX mode

Channel	Value	Function
1	0...255	Intensity red (0 % to 100 %)
2	0...255	Intensity green (0 % to 100 %)
3	0...255	Intensity blue (0 % to 100 %)
4	0...255	Intensity white (0 % to 100 %)

## 7.6 Functions in 6-channel DMX mode

Channel	Value	Function
1	0...255	Intensity red (0 % to 100 %)
2	0...255	Intensity green (0 % to 100 %)
3	0...255	Intensity blue (0 % to 100 %)
4	0...255	Intensity white (0 % to 100 %)
5	0...255	Intensity amber (0 % to 100 %)
6	0...255	Intensity UV (0 % to 100 %)



## 7.7 Functions in 9-channel DMX mode

Channel	Value	Function
1	0...255	Intensity red (0 % to 100 %)
2	0...255	Intensity green (0 % to 100 %)
3	0...255	Intensity blue (0 % to 100 %)
4	0...255	Intensity white (0 % to 100 %)
5	0...255	Intensity amber (0 % to 100 %)
6	0...255	Intensity UV (0 % to 100 %)
7	0...255	Brightness (0 % to 100 %)
8	0...255	Strobe effect, increasing speed
9	Selecting an automatic show	
	0...10	Turned off

<b>Channel</b>	<b>Value</b>	<b>Function</b>
	11...200	Colour change
	201...255	Sound-controlled show

## 7.8 Functions in 11-channel DMX mode

Channel	Value	Function
1	0...255	Intensity red (0 % to 100 %), if channel 9 = 0...10
2	0...255	Intensity green (0 % to 100 %), if channel 9 = 0...10
3	0...255	Intensity blue (0 % to 100 %), if channel 9 = 0...10
4	0...255	Intensity white (0 % to 100 %), if channel 9 = 0...10
5	0...255	Intensity amber (0 % to 100 %), if channel 9 = 0...10
6	0...255	Intensity UV (0 % to 100 %), if channel 9 = 0...10
7	0...255	Brightness (0 % to 100 %)
8	0...255	Strobe effect, increasing speed
9	0...255	Selecting an automatic show
10	0...255	Speed of the selected show, increasing, if channel 9 = 11...200
11	Sound control	

Channel	Value	Function
	0...15	Turned off
	16...255	Turned on

## 7.9 Menu overview

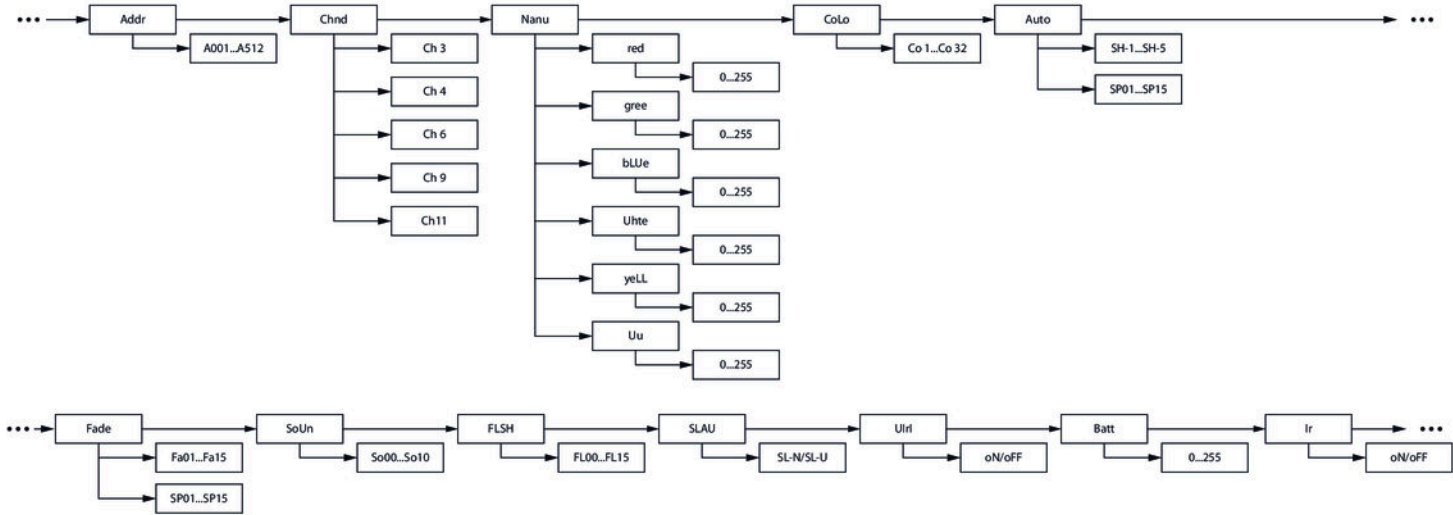

## 8 Technical specifications

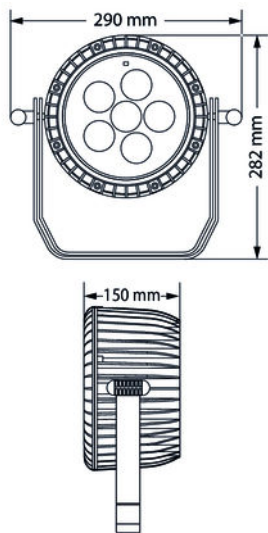

Light source	6 × 6-in-1-RGBWAUV-LEDs (15 W each)	
Optical properties	Beam angle	25 °
Control	DMX	
	Wireless DMX	
	IR remote control	
	manually via buttons and display at the unit	
Number of DMX channels	3, 4, 6, 9, 11	
Input connections	Voltage supply	Power Twist IP65 True 1
	DMX control	XLR chassis socket, 3-pin
Output connections	Voltage supply	Power Twist IP65 True 1
	DMX control	XLR chassis socket, 3-pin
Power consumption	70 W	

Supply voltage	100 – 240 V ~ 50/60 Hz	
Rechargeable battery	Battery type	Lithium-ion
	Voltage	11.1 V
	Capacity	14400 mAh
	Charging time in the device	approx. 6 h
	Operating time	approx. 7 h
Battery (remote control)	Battery type	Lithium button cell
	Voltage	3 V
Degree of protection	IP65	
Mounting options	Hanging, standing	
Dimensions (W × H × D)	290 mm × 282 mm × 150 mm	
Weight	5.5 kg	
Ambient conditions	Temperature range	-20 °C...45 °C
	Relative humidity	90 %, non-condensing

### Further information

Type	Wall decoration
Battery operation	Yes



## 9 Plug and connection assignments

### Introduction

This chapter will help you select the right cables and plugs to connect your valuable equipment so that a perfect light experience is guaranteed.

Please take our tips, because especially in 'Sound & Light' caution is indicated: Even if a plug fits into a socket, the result of an incorrect connection may be a destroyed DMX controller, a short circuit or 'just' a not working light show!

### DMX connections



The unit offers a 3-pin XLR socket for DMX output and a 3-pin XLR plug for DMX input. Please refer to the drawing and table below for the pin assignment of a suitable XLR plug.

Pin	Configuration
1	Ground, shielding
2	Signal inverted (DMX-, 'cold signal')
3	Signal (DMX+, 'hot signal')

## 10 Troubleshooting



### **NOTICE!**

#### **Possible data transmission errors**

For error-free operation make use of dedicated DMX cables and do not use ordinary microphone cables.

Never connect the DMX input or output to audio devices such as mixers or amplifiers.

In the following we list a few common problems that may occur during operation. We give you some suggestions for easy troubleshooting:

Symptom	Remedy
The unit does not work, no light.	Check the mains connection and the fuse.
No response to the DMX controller.	1. Check the DMX ports and cables for proper connection.
	2. Check the address settings and the DMX polarity.
	3. Try using another DMX controller.
	4. Check to see if the DMX cables run near or alongside to high voltage cables that may cause damage or interference to DMX interface circuits.

If the procedures recommended above do not succeed, please contact our Service Center. You can find the contact information at [www.thomann.de](http://www.thomann.de).

## 11 Cleaning

### Optical lenses

Clean the optical lenses, that are accessible from the outside, regularly in order to optimize the light output. The frequency of cleaning depends on the operating environment: wet, smoky or particularly dirty surroundings can cause more accumulation of dirt on the optics of the device.

- Clean with a soft cloth using our lamp and lens cleaner (item no. 280122).
- Always dry the parts carefully.

## 12 Protecting the environment

### Disposal of the packaging material



For the packaging, environmentally friendly materials have been chosen that can be supplied to normal recycling.

Ensure that plastic bags, packaging, etc. are properly disposed of.

Do not just dispose of these materials with your normal household waste, but make sure that they are collected for recycling. Please follow the notes and markings on the packaging.

### Disposal of batteries



Batteries do contain some hazardous chemicals so they should not be thrown away with the normal household waste. They should be returned to the manufacturer for disposal or recycled elsewhere in accordance with your local regulations.

Remove lithium batteries from the device before disposal. Protect used lithium batteries against short circuit, for example by taping the poles.

### Disposal of your old device



This product is subject to the European Waste Electrical and Electronic Equipment Directive (WEEE) in its currently valid version. Do not dispose with your normal household waste.

Dispose of this device through an approved waste disposal firm or through your local waste facility. When discarding the device, comply with the rules and regulations that apply in your country. If in doubt, consult your local waste disposal facility.



