

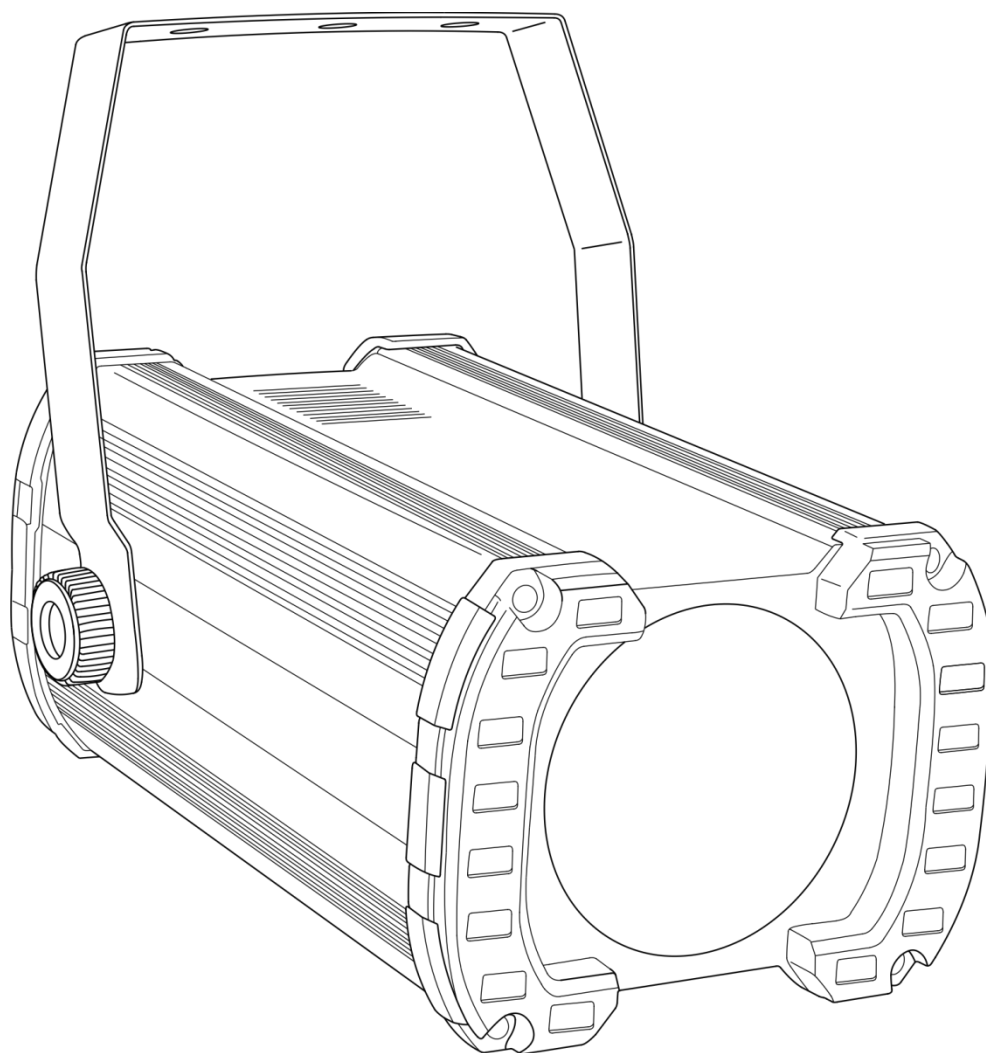

**MANUAL**



**ENGLISH**

# **Powerbeam LED 30 V1**

**Ordercode: 40143**

**Table of contents**

**Warning** ..... 2

    Safety Instructions ..... 2

    Operating Determinations ..... 4

    Rigging ..... 4

    Connection with the mains ..... 5

    Return Procedure ..... 5

    Claims ..... 5

**Description of the device** ..... 6

    Frontside ..... 6

    Backside ..... 7

**Installation** ..... 7

**Set Up and Operation** ..... 7

    Control Modes ..... 8

        One Powerbeam (Auto Run, Built-in Programs and Manual) ..... 8

        One Powerbeam (Sound-controlled) ..... 8

        Multiple Powerbeams (Master/Slave Control) ..... 8

        Multiple Powerbeams (DMX Control) ..... 9

    Fixture Linking ..... 10

    Data Cabling ..... 10

    Control Panel ..... 11

    DMX Control Mode ..... 11

    DMX Addressing ..... 11

    Menu Overview ..... 12

    Main Menu Options ..... 13

        1. Auto Run Mode ..... 13

        2. Built-in Program Mode ..... 13

        3. Static Color Mode (Manual) ..... 14

        4. Sound-controlled Mode ..... 14

        5. DMX-512 Mode ..... 14

        6. Master/Slave Mode ..... 14

        7. Test Mode ..... 15

    Remote Control ..... 15

        1. Auto Run Mode ..... 16

        2. Built-in Program Mode ..... 16

        3. Static Color Mode (Manual) ..... 16

        4. Sound-controlled Mode ..... 16

        5. DMX-512 Mode ..... 17

    DMX Channels ..... 17

        3 Channels ..... 17

        6 Channels ..... 17

        7 Channels ..... 18

**Maintenance** ..... 19

    Replacing the Fuse ..... 19

**Troubleshooting** ..... 19

    No Light ..... 19

    No Response to DMX ..... 19

**Product Specifications** ..... 21

**Dimensions** ..... 22

## Warning



**For your own safety, please read this user manual carefully  
before your initial start-up!**



### Unpacking Instructions

Immediately upon receiving this product, carefully unpack the carton and check the contents to ensure that all parts are present, and have been received in good condition. Notify the dealer immediately and retain packing material for inspection if any parts appear damaged from shipping or the carton itself shows signs of mishandling. Save the carton and all packing materials. In the event that a fixture must be returned to the factory, it is important that the fixture be returned in the original factory box and packing.

### Your shipment includes:

- Showtec Powerbeam LED 30
- IEC power cable (0,9 m)
- User manual

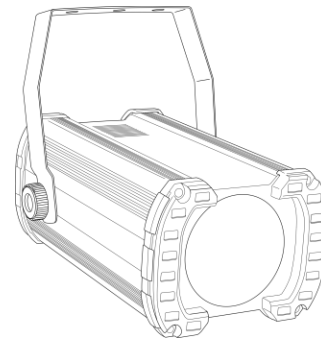

### LED Expected Lifespan

LEDs gradually decline in brightness over time. HEAT is the dominant factor that leads to the acceleration of this decline. Packaged in clusters, LEDs exhibit higher operating temperatures than in ideal or singular optimum conditions. For this reason when all color LEDs are used at their fullest intensity, life of the LEDs is significantly reduced. If improving the lifespan is of higher priority, place care in providing for lower operational temperatures. This may include climatic-environmental and the reduction of overall projection intensity.



### CAUTION!

**Keep this device away from rain and moisture!  
Unplug mains lead before opening the housing!**



### Safety Instructions

Every person involved with the installation, operation and maintenance of this device has to:

- be qualified
- follow the instructions of this manual



**CAUTION! Be careful with your operations.  
With a dangerous voltage you can suffer  
a dangerous electric shock when touching the wires!**



Before your initial start-up, please make sure that there is no damage caused by transportation. Should there be any, consult your dealer and do not use the device.

To maintain perfect condition and to ensure a safe operation, it is absolutely necessary for the user to follow the safety instructions and warning notes written in this manual.

Please consider that damages caused by manual modifications to the device are not subject to warranty.

This device contains no user-serviceable parts. Refer servicing to qualified technicians only.

**IMPORTANT:**

The manufacturer will not accept liability for any resulting damages caused by the non-observance of this manual or any unauthorized modification to the device.

- Never let the power cord come into contact with other cables! Handle the power cord and all connections with the mains with particular caution!
- Never remove warning or informative labels from the unit.
- Never use anything to cover the ground contact.
- Never lift the fixture by holding it at the projector-head, as the mechanics may be damaged.
- Never place any material over the lens.
- Never look directly into the light source.
- Never leave any cables lying around.
- Do not insert objects into air vents.
- Do not connect this device to a dimmerpack.
- Do not switch the device on and off in short intervals, as this would reduce the device's life.
- Do not touch the device's housing bare-handed during its operation. Allow the fixture to cool for at least 5 minutes before handling.
- Do not shake the device. Avoid brute force when installing or operating the device.
- Only use device indoor, avoid contact with water or other liquids.
- Only operate the fixture after having checked that the housing is firmly closed and all screws are tightly fastened.
- Only operate the device after having familiarized with its functions.
- Avoid flames and do not put close to flammable liquids or gases.
- Always keep case closed while operating.
- Always allow free air space of at least 50 cm around the unit for ventilation.
- Always disconnect power from the mains, when device is not used or before cleaning! Only handle the power cord by the plug. Never pull out the plug by tugging the power cord.
- Make sure that the device is not exposed to extreme heat, moisture or dust.
- Make sure that the available voltage is not higher than stated on the rear panel.
- Make sure that the power cord is never crimped or damaged. Check the device and the power cord from time to time.
- If the lens is obviously damaged, it has to be replaced. So that its functions are not impaired, due to cracks or deep scratches.
- If device is dropped or struck, disconnect mains power supply immediately. Have a qualified engineer inspect for safety before operating.
- If the device has been exposed to drastic temperature fluctuation (e.g. after transportation), do not switch it on immediately. The arising condensation water might damage your device. Leave the device switched off until it has reached room temperature.
- If your Showtec device fails to work properly, discontinue use immediately. Pack the unit securely (preferably in the original packing material), and return it to your Showtec dealer for service.
- For adult use only. Device must be installed out of the reach of children. Never leave the unit running unattended.
- Never attempt to bypass the thermostatic switch or fuses.
- For replacement use fuses of same type and rating only.
- The user is responsible for correct positioning and operating of the Powerbeam LED 30. The manufacturer will not accept liability for damages caused by the misuse or incorrect installation of this device.
- This device falls under protection class I. Therefore it is essential to connect the yellow/green conductor to earth.
- During the initial start-up some smoke or smell may arise. This is a normal process and does not necessarily mean that the device is defective.
- Repairs, servicing and electric connection must be carried out by a qualified technician.
- **WARRANTY:** Till one year after date of purchase.



**CAUTION! Eyedamages!!!**  
**Avoid looking directly into the lightsource!!!**  
**(meant especially for epileptics)!!!**



### Operating Determinations

- This device is not designed for permanent operation. Consistent operation breaks will ensure that the device will serve you for a long time without defects.
- The minimum distance between light-output and the illuminated surface must be more than 1 meter.
- The maximum ambient temperature  $t_a = 40^{\circ}\text{C}$  must never be exceeded.
- The relative humidity must not exceed 50 % with an ambient temperature of  $40^{\circ}\text{C}$ .
- If this device is operated in any other way, than the one described in this manual, the product may suffer damages and the warranty becomes void.
- Any other operation may lead to dangers like short-circuit, burns, electric shock, crash etc.

You endanger your own safety and the safety of others!

### Rigging

Please follow the European and national guidelines concerning rigging, trussing and all other safety issues.

Do not attempt the installation yourself !

Always let the installation be carried out by an authorized dealer !

### Procedure:

- If the Powerbeam LED 30 is lowered from the ceiling or high joists, professional trussing systems have to be used.
- Use a clamp to mount the Powerbeam LED 30, with the mounting-bracket, to the trussing system.
- The Powerbeam LED 30 must never be fixed swinging freely in the room.
- The installation must always be secured with a safety attachment, e.g. an appropriate safety net or safety-cable.
- When rigging, derigging or servicing the projector, always make sure, that the area below the installation place is blocked and staying in the area is forbidden.

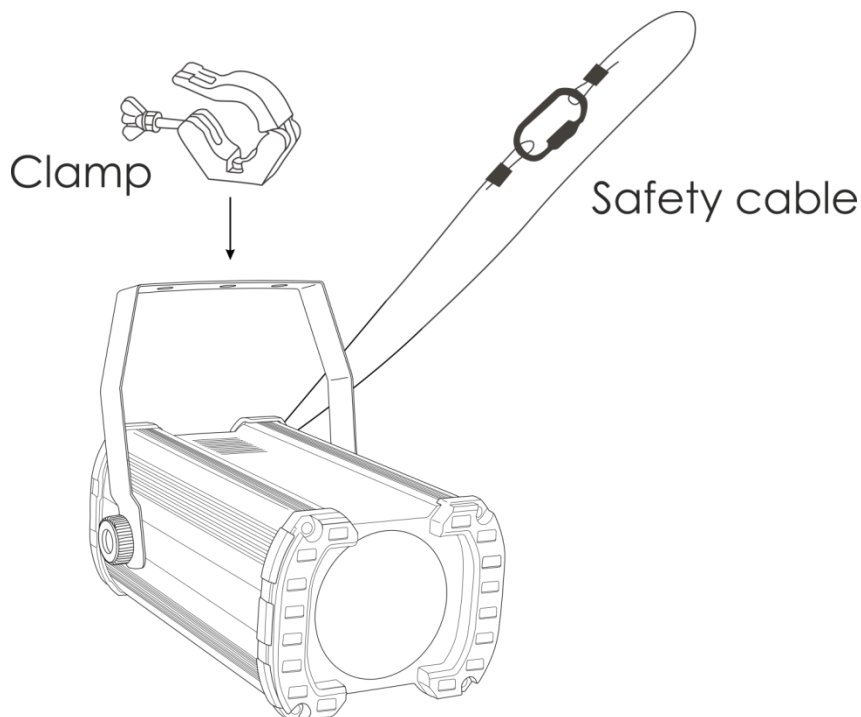

The Powerbeam 30 LED can only be mounted in a hanging position. Mounting the Powerbeam 30 LED with a clamp or any other mounting bracket is recommended, depending on the requirements of your application.

Improper installation can cause serious damage to people and property!

**Connection with the mains**

Connect the device to the mains with the power-plug.

Always pay attention, that the right color cable is connected to the right place.

International	EU Cable	UK Cable	US Cable	Pin
L	BROWN	RED	YELLOW/COPPER	PHASE
N	BLUE	BLACK	SILVER	NEUTRAL
	YELLOW/GREEN	GREEN	GREEN	PROTECTIVE GROUND

*Make sure that the device is always connected properly to the earth!*

*Improper installation can cause serious damage to people and property!*

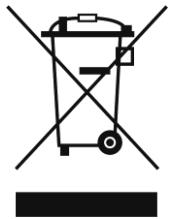

**Return Procedure**



Returned merchandise must be sent prepaid and in the original packing, call tags will not be issued. Package must be clearly labeled with a Return Authorization Number (RMA number). Products returned without an RMA number will be refused. Highlite will not accept the returned goods or any responsibility. Call Highlite 0031-455667723 or mail [aftersales@highlite.nl](mailto:aftersales@highlite.nl) and request an RMA prior to shipping the fixture. Be prepared to provide the model number, serial number and a brief description of the cause for the return. Be sure to properly pack fixture, any shipping damage resulting from inadequate packaging is the customer's responsibility. Highlite reserves the right to use its own discretion to repair or replace product(s). As a suggestion, proper UPS packing or double-boxing is always a safe method to use.

**Note: If you are given an RMA number, please include the following information on a piece of paper inside the box:**

- 01) Your name.
- 02) Your address.
- 03) Your phone number.
- 04) A brief description of the symptoms.

**Claims**

The client has the obligation to check the delivered goods immediately upon delivery for any shortcomings and/or visible defects, or perform this check after our announcement that the goods are at their disposal. Damage incurred in shipping is the responsibility of the shipper; therefore the damage must be reported to the carrier upon receipt of merchandise.

It is the customer's responsibility to notify and submit claims with the shipper in the event that a fixture is damaged due to shipping. Transportation damage has to be reported to us within one day after receipt of the delivery.

Any return shipment has to be made post-paid at all times. Return shipments must be accompanied with a letter defining the reason for return shipment. Non-prepaid return shipments will be refused, unless otherwise agreed in writing.

Complaints against us must be made known in writing or by fax within 10 working days after receipt of the invoice. After this period complaints will not be handled anymore.

Complaints will only then be considered if the client has so far complied with all parts of the agreement, regardless of the agreement of which the obligation is resulting.

## Description of the device

### Features

The Showtec Powerbeam 30 LED is a light effect with high output and great effects.

- Lightweight and robust
- No fans, low noise
- Ideal tool for entertainment applications of any size
- Creates a pin spot effect thanks to its narrow beam angle.
- Color Range: 16.7 million additive RGB colors
- DMX channels: 3, 6, 7 Channels
- Control mode: Auto Run, Built-in programs, Manual, Sound, Master/Slave, DMX-512
- Control: 4-digit LED display for easy setup
- DMX-control via standard DMX-controller
- Light Output: 1 x 30W RGB COB
- IP Rating: IP20
- Beam angle: 2°
- Dimmer: 0-100%
- Strobe: 0-20Hz
- Input Voltage: 100-240VAC. 60/50 Hz
- Power Consumption: 22W
- Housing: Metal & flame-retardant plastic
- Connections: IEC power connector 100-240VAC IN and OUT  
3-pin DMX signal connector IN and OUT
- Fuse: T1 AL/250V
- Dimensions: 340 x 240 x 280 mm (LxWxH)
- Weight: 2,8 kg

### Optional accessories:

**42704** – Infra Red Controller for Cameleon Series

### Frontside

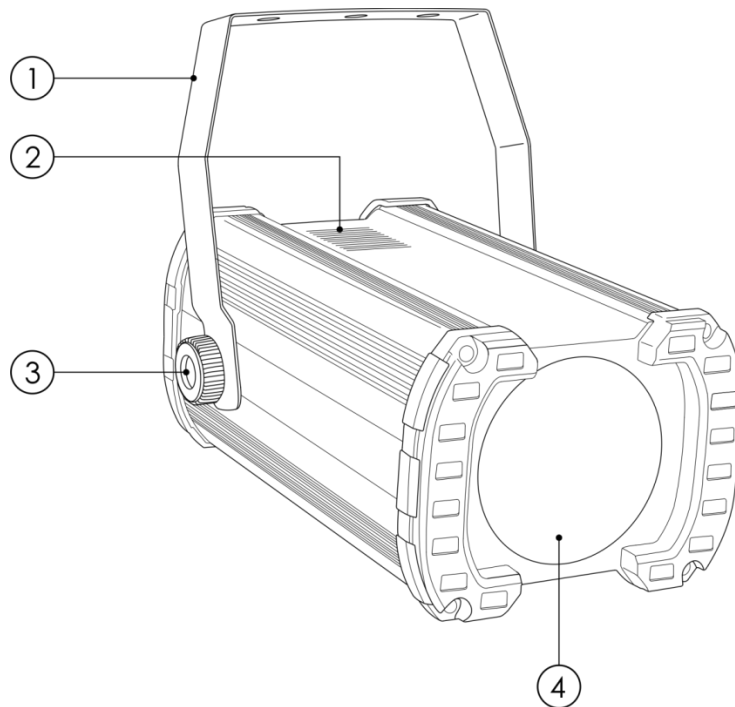

**Fig. 01**

- 01) Mounting bracket with an inclination screw
- 02) Air intake grill
- 03) Adjustment screw
- 04) LED lens

## Backside

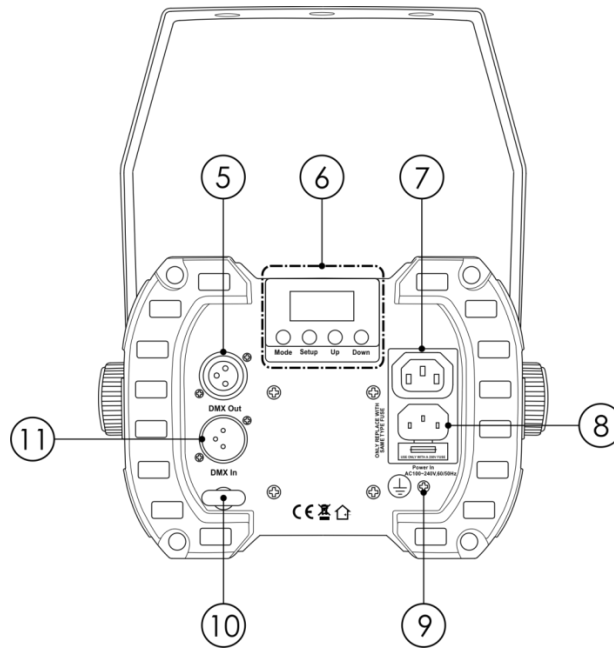

Fig. 02

- 05) 3-pin DMX signal connector OUT
- 06) LED Display + control buttons
- 07) IEC power connector 100-240VAC OUT
- 08) IEC power connector 100-240VAC IN + Fuse T1 AL/250V
- 09) Ground/earth connection
- 10) Safety eye
- 11) 3-pin DMX signal connector IN

## Installation

Remove all packing materials from the Powerbeam LED 30. Check if all foam and plastic padding is removed. Connect all cables.

**Do not supply power before the whole system is set up and connected properly.**

**Always disconnect from electric mains power supply before cleaning or servicing.**

**Damages caused by non-observance are not subject to warranty.**

## Set Up and Operation

Follow the directions below, as they pertain to your preferred operation mode.

Before plugging the unit in, always make sure that the power supply matches the product specification voltage. Do not attempt to operate a 120V specification product on 230V power, or vice versa.



## Control Modes

There are 6 modes:

- Auto Run
- Built-in programs
- Static Color (Manual)
- Sound-controlled
- Master/Slave
- DMX-512 (3CH, 6CH, 7CH)

### One Powerbeam (Auto Run, Built-in Programs and Manual)

- 01) Fasten the effect light onto firm trussing. Leave at least 0,5 meter on all sides for air circulation.
- 02) Always use a safety cable (ordercode 70140 / 70141).
- 03) Plug the end of the electric mains power cord into a proper electric power supply socket.
- 04) When the Powerbeam is not connected with a DMX-cable, it functions as a stand-alone device.
- 05) Please see page 13 and 14 for more information.

### One Powerbeam (Sound-controlled)

- 01) Fasten the effect light to a firm trussing. Leave at least 0,5 meter on all sides for air circulation.
- 02) Plug the end of the electric mains power cord into a proper electric power supply socket.
- 03) Turn on the music. If the device is set to sound-control, then the Powerbeam will react to the beat of the music. Please see page 14 for more information about the sound-control options.

### Multiple Powerbeams (Master/Slave Control)

- 01) Fasten the effect light onto firm trussing. Leave at least 0,5 meter on all sides for air circulation.
- 02) Always use a safety cable (ordercode 70140 / 70141).
- 03) Plug the end of the electric mains power cord into a proper electric power supply socket.
- 04) Use a 3-pin XLR cable to connect the Powerbeams.

The pins:



- 01) Earth
- 02) Signal (-)
- 03) Signal (+)

- 05) Link the units as shown in (Fig.03). Connect a DMX signal cable from the first unit's DMX "out" socket to the second unit's "in" socket. Repeat this process to link the second, third, and fourth units. You can use the same functions on the master device as described on pages 13-14. This means that you can set your desired operation mode on the master device and all slave devices will react the same as the master device.

### Multiple Powerbeams (Master/Slave Set Up)

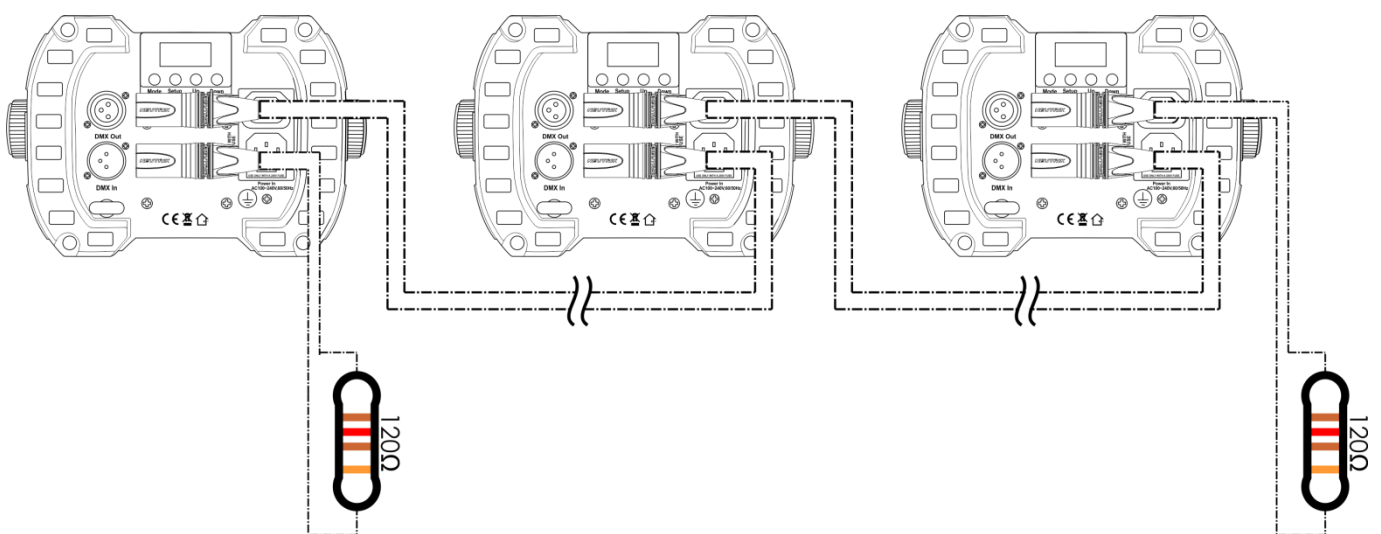
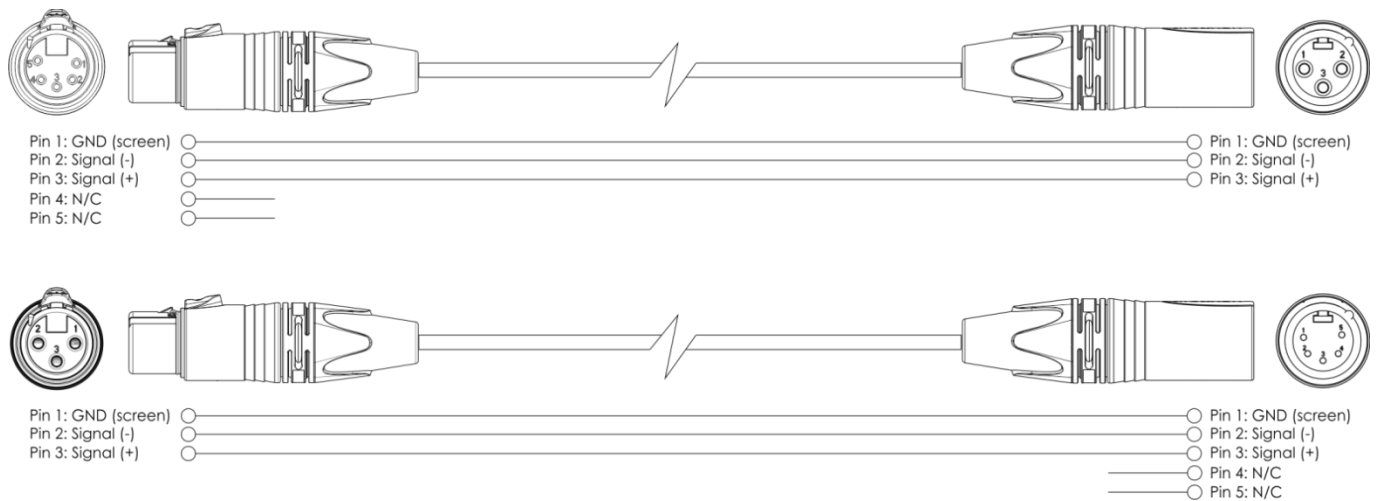

Fig. 03

**Multiple Powerbeams (DMX Control)**

- 01) Fasten the effect light onto firm trussing. Leave at least 0,5 meter on all sides for air circulation.
- 02) Always use a safety cable (ordercode 70140 / 70141).
- 03) Plug the end of the electric mains power cord into a proper electric power supply socket.
- 04) Use a 3-pin XLR cable to connect the Powerbeam LED 30 and other devices.



- 05) Link the units as shown in (Fig.04), Connect a DMX signal cable from the first unit's DMX "out" socket to the second unit's "in" socket. Repeat this process to link the second, third, and fourth units.
- 06) Supply electric power: Plug electric mains power cords into each unit's IEC socket, then plug the other end of the mains power cord into proper electric power supply sockets, starting with the first unit. Do not supply power before the whole system is set up and connected properly.

**Multiple Powerbeams (DMX Set Up)**

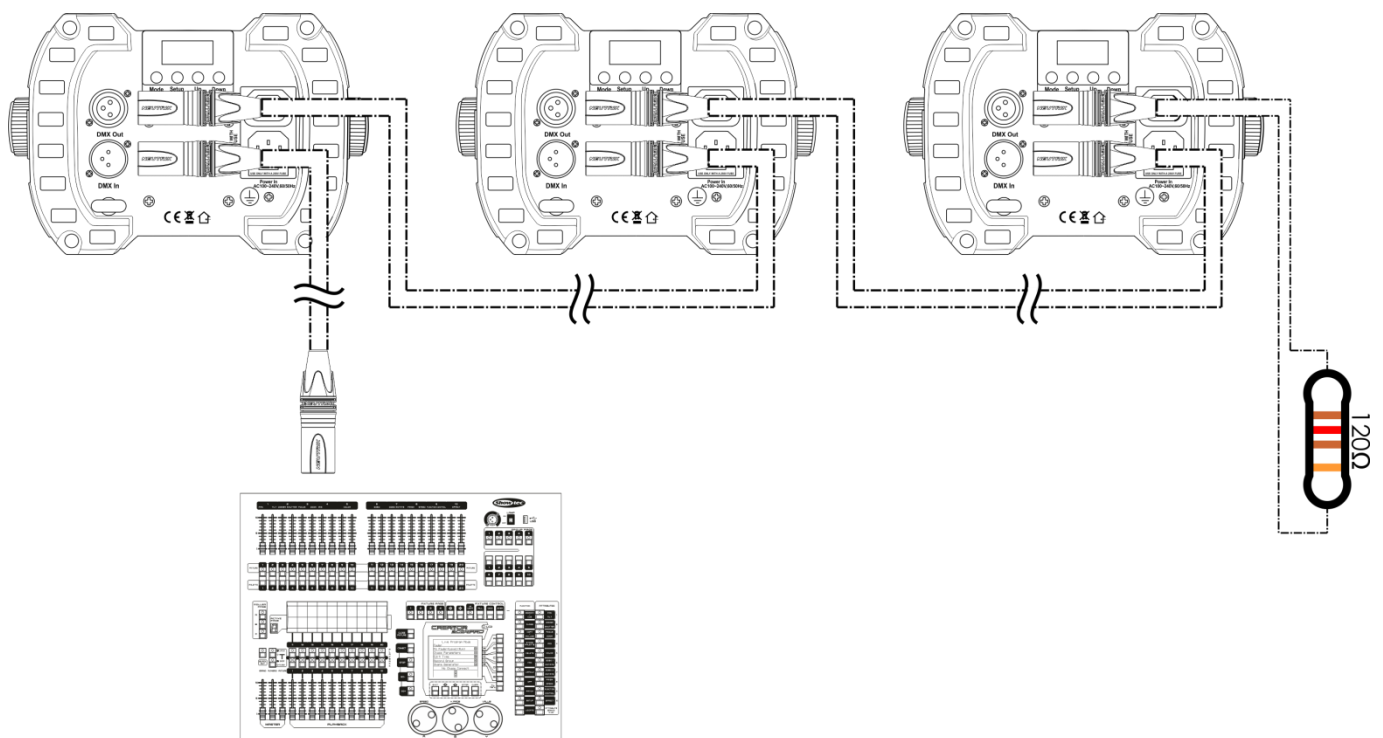

**Fig. 04**

## Fixture Linking

You will need a serial data link to run light shows of one or more fixtures using a DMX-512 controller or to run synchronized shows on two or more fixtures set to a master/slave operating mode. The combined number of channels required by all the fixtures on a serial data link determines the number of fixtures the data link can support.

**Important:** Fixtures on a serial data link must be daisy chained in one single line. To comply with the EIA-485 standard no more than 30 devices should be connected on one data link. Connecting more than 30 fixtures on one serial data link without the use of a DMX optically isolated splitter may result in deterioration of the digital DMX signal.



Maximum recommended DMX data link distance: 100 meters

Maximum recommended number of Powerbeams on a DMX data link: 30 fixtures

## Data Cabling

To link fixtures together you must obtain data cables. You can purchase DAP Audio certified DMX cables directly from a dealer/distributor or construct your own cable. If you choose to create your own cable please use data-grade cables that can carry a high quality signal and are less prone to electromagnetic interference.

### DAP Audio DMX Data Cables

- DAP Audio Basic microphone cable for allround use. bal. XLR/M 3-pin > XLR/F 3-pin. **Ordercode** FL01150 (1,5 m), FL013 (3 m), FL016 (6 m), FL0110 (10 m), FL0115 (15 m), FL0120 (20 m).
- DAP Audio X-type data cable XLR/M 3-pin > XLR/F 3-pin. **Ordercode** FLX0175 (0,75 m), FLX01150 (1,5 m), FLX013 (3 m), FLX016 (6 m), FLX0110 (10 m).
- DAP Audio cable for the demanding user with exceptional audio-qualities and connector made by Neutrik®. **Ordercode** FL71150 (1,5 m), FL713 (3 m), FL716 (6 m), FL7110 (10 m).
- DAP Audio cable for the demanding user with exceptional audio-qualities and connector made by Neutrik®. **Ordercode** FL7275 (0,75 m), FL72150 (1,5 m), FL723 (3 m), FL726 (6 m), FL7210 (10 m).
- DAP Audio 110 Ohm cable with digital signal transmission. **Ordercode** FL0975 (0,75 m), FL09150 (1,5 m), FL093 (3 m), FL096 (6 m), FL0910 (10 m), FL0915 (15 m), FL0920 (20 m).

The Powerbeam LED 30 can be operated with a controller in **control mode** or without the controller in **stand-alone mode**.

## Control Panel

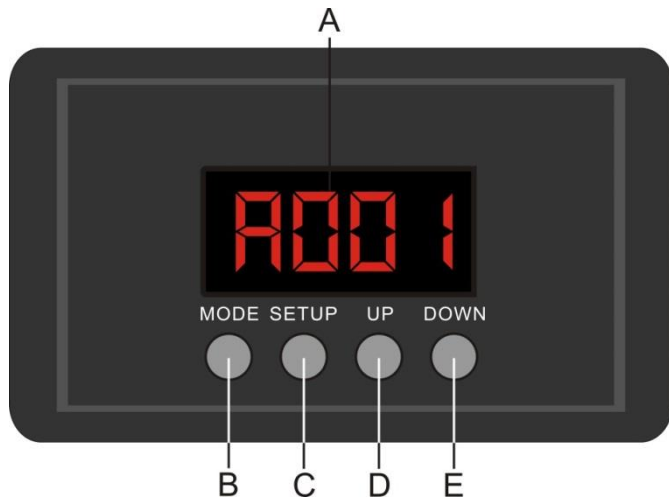

- A) LED display
- B) MODE button
- C) SETUP button
- D) UP button
- E) DOWN button

Fig. 05

## DMX Control Mode

The fixtures are individually addressed on a data-link and connected to the controller. When a DMX signal is present, the DMX LED will blink.

The fixtures respond to the DMX signal from the controller. (When you select the DMX address and save it, the controller will display the saved DMX address the next time.)

## DMX Addressing

The control panel on the front side of the base allows you to assign the DMX fixture address, which is the first channel from which the Powerbeam will respond to the controller.

Please note when you use the controller, the unit has **7** channels.

When using multiple Powerbeams make sure you set the DMX addresses right.

Therefore, the DMX address of the first Powerbeam should be **1(001)**; the DMX address of the second Powerbeam should be **1+7=8 (008)**; the DMX address of the third Powerbeam should be **8+7=15 (015)**, etc.

Please, be sure that you do not have any overlapping channels in order to control each Powerbeam correctly.

If two or more Powerbeams are addressed similarly, they will work similarly.

## Controlling:

After having addressed all Powerbeam fixtures, you may now start operating these via your lighting controller.

**Note:** After switching on, the Powerbeam LED 30 will automatically detect whether DMX 512 data is received or not. If there is no data received at the DMX-input, the DMX LED will not blink.

The problem may be:

- The XLR cable from the controller is not connected with the input of the Powerbeam LED 30.
- The controller is switched off or defective, the cable or connector is defective, or the signal wires are swapped in the input connector.

**Note:** It is necessary to insert an XLR termination plug (with 120 Ohm) in the last fixture in order to ensure proper transmission on the DMX data link.

## Display Off after 10 seconds

When no button is pressed for 10 seconds, the display will turn off.

To light up the display, you have to press the MODE, SETUP, UP or DOWN buttons.

Once you have pressed the button, the display will light up.

Menu Overview

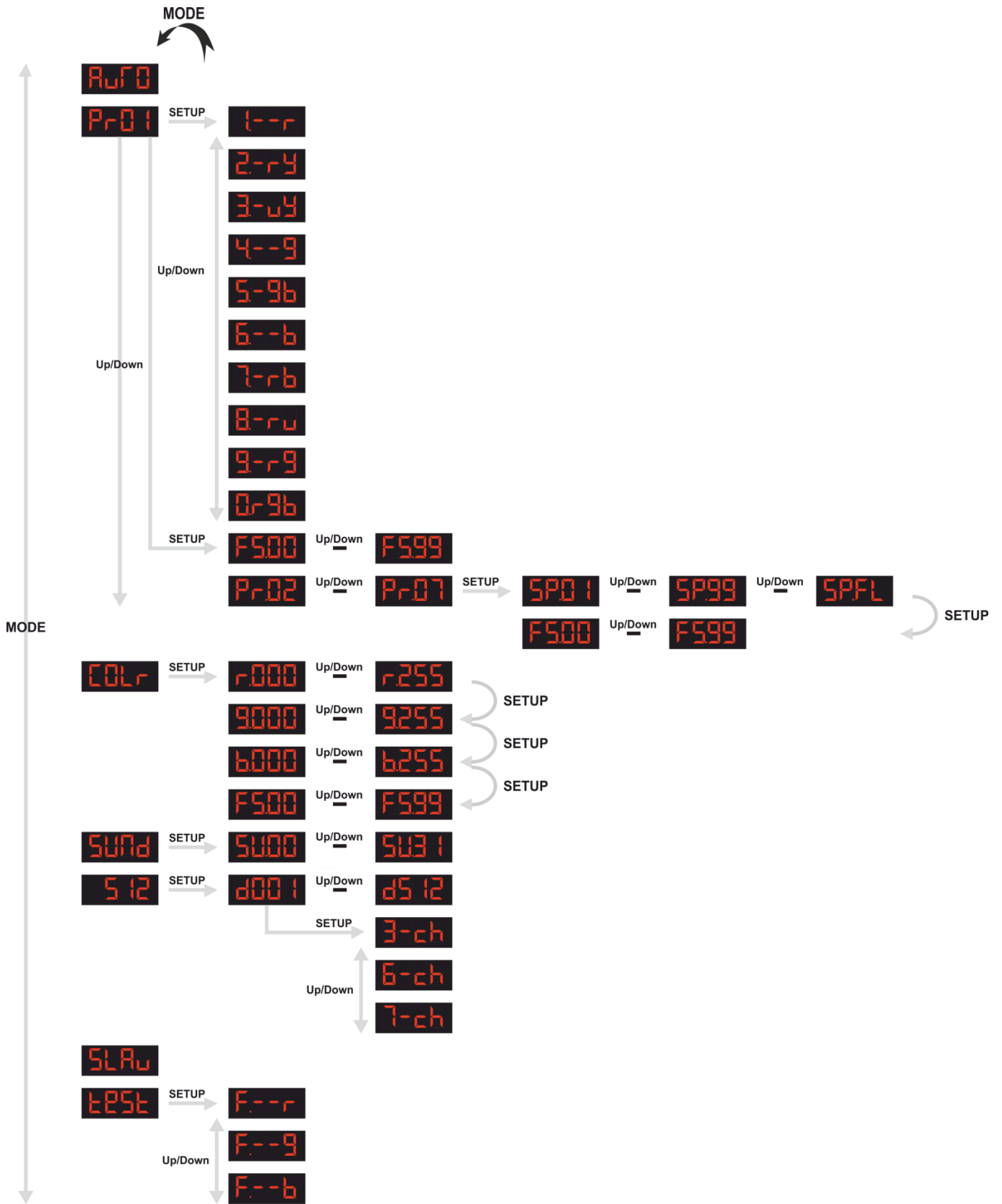

## Main Menu Options

<b>AuRD</b>	Auto Run Mode
<b>Pr01</b>	Built-in Program Mode
<b>COLr</b>	Static Color Mode (Manual)
<b>SUNd</b>	Sound-controlled Mode
<b>512</b>	DMX-512 Mode
<b>SLAv</b>	Master/Slave Mode
<b>TEST</b>	Test Mode

### 1. Auto Run Mode

- 01) Press the **MODE** button until the display shows **AuRD**.
- 02) The Powerbeam will now run its pre-programmed color flow effect, at variable speed.

### 2. Built-in Program Mode

- 01) Press the **MODE** button until the display shows one of the available built-in programs:  
**Pr01** <sup>Up/Down</sup> **Pr07**
- 02) Press the **UP/DOWN** buttons to toggle between the programs.
- 03) When the display shows **Pr01**, press the **SETUP** button to proceed to selection of the built-in color presets.
- 04) Press the **UP/DOWN** buttons to toggle between the following color presets:
  - 1--r** Red
  - 2--y** Orange
  - 3--l** Light Yellow
  - 4--g** Green
  - 5--c** Cyan
  - 6--b** Blue
  - 7--p** Purple
  - 8--p** Pink
  - 9--y** Yellow
  - 0--w** White
- 05) Press the **SETUP** button again to proceed to the strobe settings.
- 06) Press the **UP/DOWN** buttons to increase/decrease the strobe intensity. The adjustment range is between **F500** <sup>Up/Down</sup> **F599**, from OFF to high intensity.
- 07) Return to step 2. When the display shows **Pr02** <sup>Up/Down</sup> **Pr07**, press the **SETUP** button to proceed to the built-in program speed settings.

- 08) Press the **UP/DOWN** buttons to adjust the running speed of the built-in programs. The adjustment range is between **SP01** <sup>Up/Down</sup> **SP99** (from slow to fast), and **SPFL** (full ON).
- 09) Press the **SETUP** button again to proceed to the strobe settings.
- 10) Press the **UP/DOWN** buttons to increase/decrease the strobe intensity. The adjustment range is between **F500** <sup>Up/Down</sup> **F599**, from OFF to high intensity.

### 3. Static Color Mode (Manual)

- 01) Press the **MODE** button until the display shows **COLr**.
- 02) Repeatedly press the **SETUP** button to toggle between the following settings:
 

<b>r000</b> <sup>Up/Down</sup> <b>r255</b>	Red color intensity
<b>g000</b> <sup>Up/Down</sup> <b>g255</b>	Green color intensity
<b>b000</b> <sup>Up/Down</sup> <b>b255</b>	Blue color intensity
<b>F500</b> <sup>Up/Down</sup> <b>F599</b>	Strobe intensity
- 03) Press the **UP/DOWN** buttons to increase/decrease the intensity of the red, green and blue LEDs. The adjustment range is between 0-255, from low to high intensity.
- 04) The adjustment range of the strobe intensity is between **F500** <sup>Up/Down</sup> **F599**, from OFF to high intensity.

You can combine Red, Green and Blue to create an infinite range of colors (000-255).

### 4. Sound-controlled Mode

- 01) Press the **MODE** button until the display shows **SUND**.
- 02) Press the **SETUP** button to enter the menu.
- 03) Press the **UP/DOWN** buttons to set the sound sensitivity. The adjustment range is between **SU00** <sup>Up/Down</sup> **SU31**, from low to high sensitivity.
- 04) The device will now react to the beat of the background music.

### 5. DMX-512 Mode

- 01) Press the **MODE** button until the display shows **512**.
- 02) Press the **SETUP** button to enter the menu.
- 03) Press the **UP/DOWN** buttons to set the desired DMX address. The adjustment range is between **0001** <sup>Up/Down</sup> **0512**.
- 04) Press the **SETUP** button again to proceed to the channel mode settings.
- 05) Press the **UP/DOWN** buttons to choose one of the 3 available channel modes:
 

<b>3-ch</b>	3 channels
<b>6-ch</b>	6 channels
<b>7-ch</b>	7 channels

### 6. Master/Slave Mode

- 01) Press the **MODE** button until the display shows **SLAV**.
- 02) The device is now operating in Slave Mode. It means that it will react the same as the master device.

7. Test Mode

- 01) Press the **MODE** button until the display shows **TEST**.
- 02) Press the **SETUP** button to enter the menu.
- 03) Press the **UP/DOWN** buttons to test the following aspects of the device's performance:

**F--r** Red LED test

**F--g** Green LED test

**F--b** Blue LED test

Remote Control

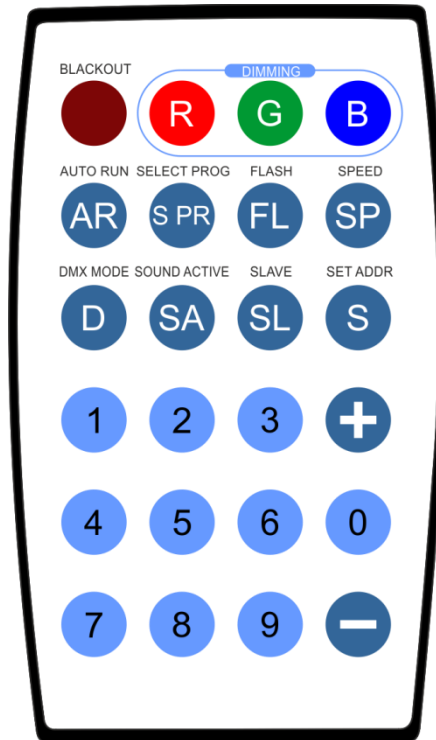



















Button	Function	Description
	Blackout	Switch the device ON or OFF
	LED	Adjust the LED intensity
	Auto Run Mode	Activate Auto Run Mode
	Built-in programs	Activate Built-in programs
	Strobe	Activate Strobe
	Speed	Set the program running speed
	DMX Mode	Activate DMX Mode
	Sound-controlled Mode	Activate Sound-controlled Mode
	Master/Slave Mode	Activate Master/Slave Mode
	Set Address	Set the desired DMX address
	Numeric buttons	Choose programs/set DMX address
	Plus/Minus	Increase/decrease the parameter values











**1. Auto Run Mode**

- 01) Press the  button to activate the Auto Run Mode. The display will show .
- 02) The device will now run the preprogrammed automatic color flow effect.

**2. Built-in Program Mode**

- 01) Press the  button to activate the Built-in programs.
- 02) Press the   buttons to choose one of the built-in programs:   .
- 03) Press the   buttons to increase/decrease the running speed of the desired built-in program. The adjustment range is between   , from slow to fast.
- 04) Press the  button to activate the strobe.
- 05) Press the   to increase/decrease the strobe intensity. The adjustment range is between   , from slow to fast.
- 06) Press the  button again to switch the strobe OFF.

**3. Static Color Mode (Manual)**

- 01) Press one of the    buttons to enter the LED intensity settings.
- 02) Press the   buttons to increase/decrease the LED intensity. The adjustment range for each LED is between 0-255, from dark to full ON.
- 03) Press one of the    buttons to select one of the following color options:



Red



Orange



Light Yellow



Green



Cyan



Blue



Purple



Pink









Yellow





White

**4. Sound-controlled Mode**

- 01) Press the  button to activate the Sound-controlled Mode. The display will show .
- 02) Press the   buttons to increase/decrease the sound sensitivity. The adjustment range is between   .

**5. DMX-512 Mode**

- 01) Press the **D** button to activate the DMX-512 Mode. The LEDs will blink once.
- 02) Press the **S** button to proceed to the DMX address settings. The LEDs will blink 3 times.
- 03) Now, you have 6 seconds to press 3 out of 10 numeric buttons **0-9** in order to set the desired DMX address.
- 04) Each press of the button will be accompanied with a single LED blink.
- 05) Once the desired DMX address has been set, it will appear promptly on the display. The adjustment range is between  <sup>Up/Down</sup> .

**DMX Channels**

**3 Channels**

**Channel 1 – Red LED**

0-255 Gradual adjustment Red from 0 – 100%

**Channel 2 – Green LED**

0-255 Gradual adjustment Green from 0 – 100%

**Channel 3 – Blue LED**

0-255 Gradual adjustment Blue from 0 – 100%

**6 Channels**

**Channel 1 – Dimmer**

0-255 From dark to brightest

**Channel 2 – Red LED  Dimmer must be open **

0-255 Gradual adjustment Red from 0 – 100%

**Channel 3 – Green LED  Dimmer must be open **

0-255 Gradual adjustment Green from 0 – 100%

**Channel 4 – Blue LED  Dimmer must be open **

0-255 Gradual adjustment Blue from 0 – 100%

**Channel 5 – Sound-controlled Mode**

0-10 Not functional

11-255 Sound-controlled Mode

**Channel 6 – Strobe  CH5 must be set between 0-10 **

0-10 Not functional

11-255 Strobe intensity, from slow to fast

**Channel 6 – Sound Sensitivity  CH5 must be set between 11-255 **

0-255 Sound sensitivity

## 7 Channels

### Channel 1 – Dimmer

0-255 From dark to brightest

### Channel 2 – Red LED Dimmer must be open

0-255 Gradual adjustment Red from 0 – 100%

### Channel 3 – Green LED Dimmer must be open

0-255 Gradual adjustment Green from 0 – 100%

### Channel 4 – Blue LED Dimmer must be open

0-255 Gradual adjustment Blue from 0 – 100%

### Channel 5 – Functions

0-24	Static Color Mode
25-49	Color flow effect
50-74	Built-in program 2
75-99	Built-in program 3
100-124	Built-in program 4
125-149	Built-in program 5
150-174	Built-in program 6
175-199	Built-in program 7
200-255	Sound-controlled Mode

### Channel 6 – Program Speed CH5 must be set between 50-199

0-255 Built-in program speed, from slow to fast

### Channel 6 – Sound Sensitivity CH5 must be set between 200-255

0-255 Sound sensitivity, from low to high sensitivity

### Channel 7 – Strobe CH5 must be set between 50-199

0-255 Strobe intensity, from slow to fast

## Maintenance

---

The Showtec Powerbeam LED 30 requires almost no maintenance. However, you should keep the unit clean. Otherwise, the fixture's light-output will be significantly reduced. Disconnect the mains power supply and then wipe the cover with a damp cloth. Wipe the front glass panel clean with glass cleaner and a soft cloth. Do not use alcohol or solvents. The front glass panel will require weekly cleaning, as smoke-fluid tends to build up residues, reducing the light-output very quickly. Do not immerse in liquid. Keep connections clean. Disconnect electric power, and then wipe the DMX and audio connections with a damp cloth. Make sure connections are thoroughly dry before linking equipment or supplying electric power.

The operator has to make sure that safety-relating and machine-technical installations are to be inspected by an expert after every year in the course of an acceptance test.

The operator has to make sure that safety-relating and machine-technical installations are to be inspected by a skilled person once a year.

The following points have to be considered during the inspection:

- 01) All screws used for installing the device or parts of the device have to be tightly connected and must not be corroded.
- 02) There may not be any deformations on housings, fixations and installation spots.
- 03) Mechanically moving parts like axles, eyes and others may not show any traces of wearing.
- 04) The electric power supply cables must not show any damages or material fatigue.

## Replacing the Fuse

Power surges, short-circuit or inappropriate electrical power supply may cause a fuse to burn out.

If the fuse burns out, the product will not function whatsoever. If this happens, follow the directions below:

- 01) Unplug the unit from electric power source.
- 02) Insert a flat-headed screwdriver into a slot in the fuse cover. Gently pry up the fuse cover. The fuse will come out.
- 03) Remove the used fuse. If brown or unclear, it is burned out.
- 04) Insert the replacement fuse into the holder. Reinsert the fuse cover. Be sure to use a fuse of the same type and specification. See the product specification label for details.

## Troubleshooting

---

### No Light

This troubleshooting guide is meant to help solve simple problems.

If a problem occurs, carry out the steps below in sequence until a solution is found. Once the unit operates properly, do not carry out following steps.

If the light effect does not operate properly, refer servicing to a technician.

Response: Suspect three potential problem areas as: the power supply, the LED, the fuse.

- 01) Power supply. Check if the unit is plugged into an appropriate power supply.
- 02) The LEDs. Return the Powerbeam LED 30 to your Showtec dealer.
- 03) The fuse. See page 19 for replacing the fuse.
- 04) If all of the above appears to be O.K., plug the unit in again.
- 05) If you are unable to determine the cause of the problem, do not open the Powerbeam LED 30, as this may damage the unit and the warranty will become void.
- 06) Return the device to your Showtec dealer.

### No Response to DMX

Response: Suspect the DMX cable or connectors, a controller malfunction, a light effect DMX card malfunction.

- 01) Check the DMX setting. Make sure that DMX addresses are correct.
- 02) Check the DMX cable: Unplug the unit; change the DMX cable; then reconnect to electrical power. Try your DMX control again.
- 03) Determine whether the controller or light effect is at fault. Does the controller operate properly with other DMX products? If not, take the controller in for repair. If so, take the DMX cable and the light effect to a qualified technician.

<b>Problem</b>	<b>Probable cause(s)</b>	<b>Solution</b>
One or more fixtures do not function at all	No power to the fixture	<ul style="list-style-type: none"> <li>• Check if power is switched on and cables are plugged in</li> </ul>
	Primary fuse blown	<ul style="list-style-type: none"> <li>• Replace fuse</li> </ul>
Fixtures reset correctly, but all respond erratically or not at all to the controller	The controller is not connected.	<ul style="list-style-type: none"> <li>• Connect controller.</li> </ul>
	3-pin XLR Out of the controller does not match XLR Out of the first fixture on the link (i.e. signal is reversed)	<ul style="list-style-type: none"> <li>• Install a phase reversing cable between the controller and the first fixture on the link</li> </ul>
Fixtures reset correctly, but some respond erratically or not at all to the controller	Poor data quality	<ul style="list-style-type: none"> <li>• Check data quality. If much lower than 100 percent, the problem may be a bad data link connection, poor quality or broken cables, missing termination plug, or a defective fixture disturbing the link</li> </ul>
	Bad data link connection	<ul style="list-style-type: none"> <li>• Inspect connections and cables. Correct poor connections. Repair or replace damaged cables</li> </ul>
	Data link not terminated with 120 Ohm termination plug	<ul style="list-style-type: none"> <li>• Insert termination plug in output jack of the last fixture on the link</li> </ul>
	Incorrect addressing of the fixtures	<ul style="list-style-type: none"> <li>• Check address setting</li> </ul>
	One of the fixtures is defective and disturbs data transmission on the link	<ul style="list-style-type: none"> <li>• Bypass one fixture at a time until normal operation is restored: unplug both connectors and connect them directly together.</li> <li>• Have the defective fixture serviced by a qualified technician</li> </ul>
	3-pin XLR Out on the fixtures does not match (pins 2 and 3 reversed)	<ul style="list-style-type: none"> <li>• Install a phase-reversing cable between the fixtures or swap pin 2 and 3 in the fixture that behaves erratically</li> </ul>
No light or lamp cuts out intermittently	Fixture is too hot	<ul style="list-style-type: none"> <li>• Allow the fixture to cool down</li> <li>• Clean the fan</li> <li>• Make sure air vents in control panel and the front lens are not blocked</li> <li>• Turn up the air conditioning</li> </ul>
	LEDs damaged	<ul style="list-style-type: none"> <li>• Disconnect the fixture and return it to your dealer</li> </ul>
	The power supply settings do not match local AC voltage and frequency	<ul style="list-style-type: none"> <li>• Disconnect fixture. Check settings and correct if necessary</li> </ul>

## Product Specifications

Model:	Showtec Powerbeam LED 30
Input Voltage:	100-240 VAC, 60/50Hz
Power consumption:	22W
DMX linking:	30pcs
Fuse:	T1A/250V
Dimensions:	340 x 240 x 280 mm (LxWxH)
Weight:	2,8 kg
<b>Operating and Programming:</b>	
Signal pin OUT:	Pin 1 (earth), pin 2 (-), pin 3 (+)
DMX Mode:	3, 6, 7
Signal input:	3-pin XLR male
Signal output:	3-pin XLR female
<b>Electro-mechanical effects:</b>	
LED Quantity:	1 x 30W RGB COB
Color mixing:	RGB
Color Range:	16.7 million additive colors
Beam angle:	2°
Dimmer: 0-100%	0-100%
Strobe: 0-20Hz	0-20Hz
DMX-control:	via standard DMX-controller
Onboard:	4-digit LED display for easy setup
Control:	Auto Run, Built-in programs, Manual, Sound, Master/Slave, DMX-512
Housing:	Metal & Flame-retardant plastic
IP Rating:	IP20
Connections:	Dedicated Schuko to IEC & Data connector
Included:	IEC power cable (0,9 m) and IR remote control
Max. ambient temperature $t_a$ :	40°C
Max. housing temperature $t_B$ :	80°C
<b>Minimum distance:</b>	
Minimum distance from flammable surfaces:	0,5 m
Minimum distance to lighted object:	1 m

Design and product specifications are subject to change without prior notice.



Website: [www.Showtec.info](http://www.Showtec.info)  
 Email: [service@highlite.nl](mailto:service@highlite.nl)

## Dimensions

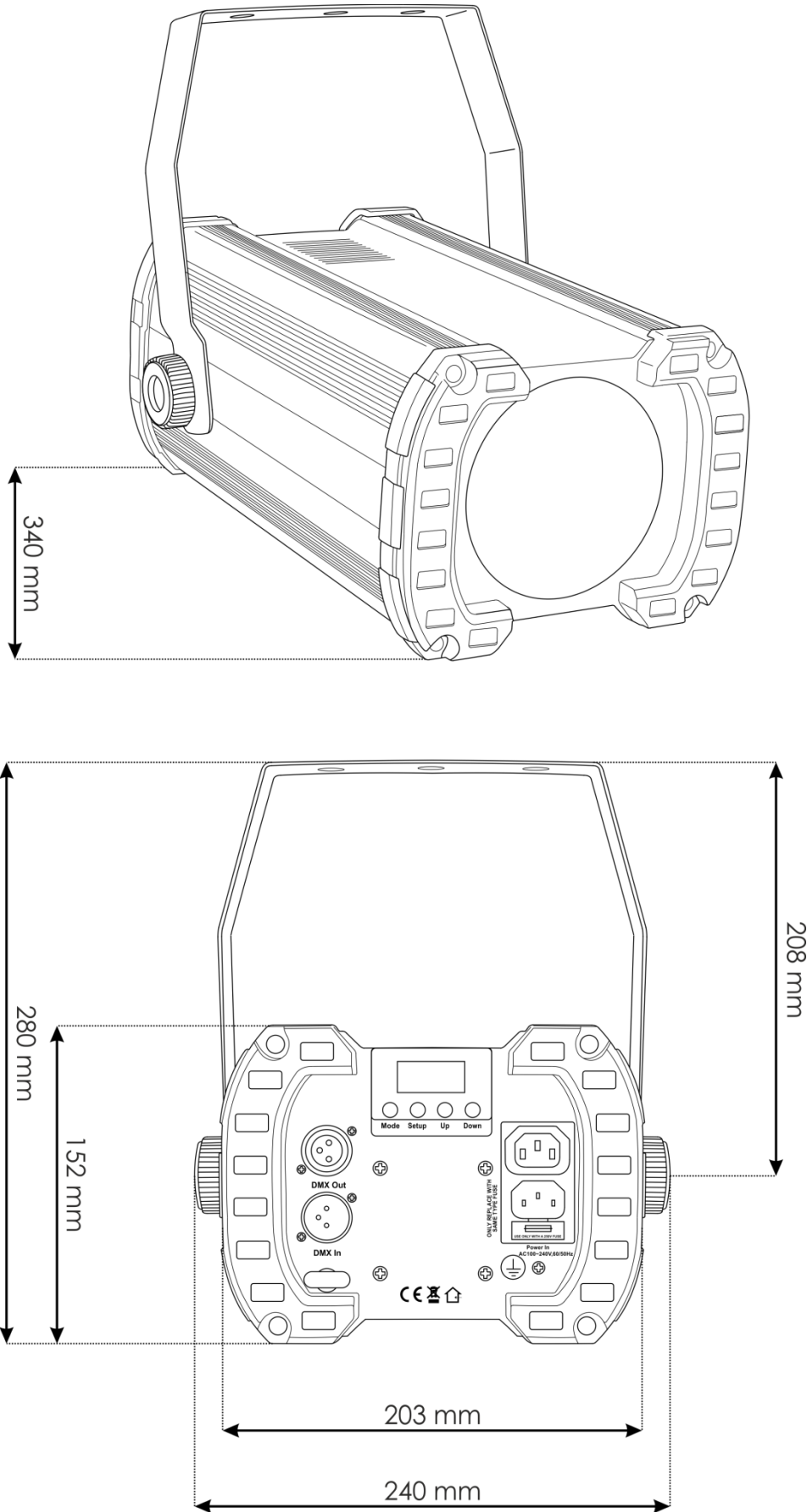



©2015 Showtec