



Compact LED-Bar  
4 TriPAR CLB4  
LED lighting set

Musikhaus Thomann  
Thomann GmbH  
Hans-Thomann-Straße 1  
96138 Burgebrach  
Germany  
Telephone: +49 (0) 9546 9223-0  
E-mail: [info@thomann.de](mailto:info@thomann.de)  
Internet: [www.thomann.de](http://www.thomann.de)

22.05.2020, ID: 298052 (V3)

# Table of contents

<b>1</b>	<b>General information</b> .....	<b>5</b>
	1.1 Further information.....	6
	1.2 Notational conventions.....	7
	1.3 Symbols and signal words.....	7
<b>2</b>	<b>Safety instructions</b> .....	<b>10</b>
<b>3</b>	<b>Features</b> .....	<b>18</b>
<b>4</b>	<b>Installation</b> .....	<b>19</b>
<b>5</b>	<b>Setup</b> .....	<b>25</b>
<b>6</b>	<b>Connections and controls</b> .....	<b>28</b>
<b>7</b>	<b>Operation</b> .....	<b>34</b>
	7.1 Starting up the device.....	34
	7.2 Device functions.....	34
	7.3 Foot switch.....	34
	7.4 Remote control.....	35
	7.5 Operating controls on the unit.....	38

7.6	Menu diagram.....	45
7.7	Functions in 2-channel DMX mode.....	47
7.8	Functions in 3-channel DMX mode.....	48
7.9	Functions in 4-channel DMX mode.....	49
7.10	Functions in 7-channel DMX mode.....	49
7.11	Functions in 8-channel DMX mode .....	51
7.12	Functions in 14-channel DMX mode.....	52
<b>8</b>	<b>Technical specifications.....</b>	<b>54</b>
<b>9</b>	<b>Plug and connection assignments.....</b>	<b>57</b>
<b>10</b>	<b>Troubleshooting.....</b>	<b>58</b>
<b>11</b>	<b>Cleaning.....</b>	<b>60</b>
<b>12</b>	<b>Protecting the environment.....</b>	<b>61</b>

# 1 General information

This user manual contains important information on the safe operation of the device. Read and follow all safety notes and all instructions. Save this manual for future reference. Make sure that it is available to all persons using this device. If you sell the device to another user, be sure that they also receive this manual.

Our products and user manuals are subject to a process of continuous development. We therefore reserve the right to make changes without notice. Please refer to the latest version of the user manual which is ready for download under [www.thomann.de](http://www.thomann.de).

## 1.1 Further information

On our website ([www.thomann.de](http://www.thomann.de)) you will find lots of further information and details on the following points:

Download	This manual is also available as PDF file for you to download.
Keyword search	Use the search function in the electronic version to find the topics of interest for you quickly.
Online guides	Our online guides provide detailed information on technical basics and terms.
Personal consultation	For personal consultation please contact our technical hotline.
Service	If you have any problems with the device the customer service will gladly assist you.

## 1.2 Notational conventions

This manual uses the following notational conventions:

### Letterings

The letterings for connectors and controls are marked by square brackets and italics.

**Examples:** *[VOLUME]* control, *[Mono]* button.



### Displays

Texts and values displayed on the device are marked by quotation marks and italics.



**Examples:** *'24ch'*, *'OFF'*.

## 1.3 Symbols and signal words

In this section you will find an overview of the meaning of symbols and signal words that are used in this manual.

Signal word	Meaning
<b>DANGER!</b>	This combination of symbol and signal word indicates an immediate dangerous situation that will result in death or serious injury if it is not avoided.
<b>WARNING!</b>	This combination of symbol and signal word indicates a possible dangerous situation that can result in death or serious injury if it is not avoided.
<b>NOTICE!</b>	This combination of symbol and signal word indicates a possible dangerous situation that can result in material and environmental damage if it is not avoided.
Warning signs	Type of danger
	Warning – high-voltage.
	Warning – dangerous optical radiation.



Warning signs	Type of danger
	<p>Warning – suspended load.</p>
	<p>Warning – danger zone.</p>

## 2 Safety instructions

### **Intended use**

This device is intended for use as an electronic lighting effect by means of LED technology. The device is designed for professional use and is not suitable for use in households. Use the device only as described in this user manual. Any other use or use under other operating conditions is considered to be improper and may result in personal injury or property damage. No liability will be assumed for damages resulting from improper use.

This device may be used only by persons with sufficient physical, sensorial, and intellectual abilities and having corresponding knowledge and experience. Other persons may use this device only if they are supervised or instructed by a person who is responsible for their safety.

Extend the life of the device by regular breaks in operation and avoid switching it on and off frequently. This device is not suitable for continuous use.

**Safety****DANGER!****Danger for children**

Ensure that plastic bags, packaging, etc. are disposed of properly and are not within reach of babies and young children. Choking hazard!

Ensure that children do not detach any small parts (e.g. knobs or the like) from the unit. They could swallow the pieces and choke!

Never let children unattended use electrical devices.

**DANGER!****Electric shock caused by high voltages inside**

Within the device there are areas where high voltages may be present. Never remove any covers.

There are no user-serviceable parts inside.

Do not use the device if covers, protectors or optical components are missing or damaged.



### **DANGER!**

#### **Electric shock caused by short-circuit**

Always use proper ready-made insulated mains cabling (power cord) with a protective contact plug. Do not modify the mains cable or the plug. Failure to do so could result in electric shock/death or fire. If in doubt, seek advice from a registered electrician.



### **WARNING!**

#### **Eye damage caused by high light intensity**

Never look directly into the light source.



### **WARNING!**

#### **Risk of epileptic shock**

Strobe lighting can trigger seizures in photosensitive epilepsy. Sensitive persons should avoid looking at strobe lights.



**NOTICE!**

**Risk of fire**

Do not block areas of ventilation. Do not install the device near any direct heat source. Keep the device away from naked flames.



### **NOTICE!**

#### **Operating conditions**

This device has been designed for indoor use only. To prevent damage, never expose the device to any liquid or moisture. Avoid direct sunlight, heavy dirt, and strong vibrations.

Only operate the device within the ambient conditions specified in the chapter 'Technical specifications' of this user manual. Avoid heavy temperature fluctuations and do not switch the device on immediately after it was exposed to temperature fluctuations (for example after transport at low outside temperatures).

Dust and dirt inside can damage the unit. When operated in harmful ambient conditions (dust, smoke, nicotine, fog, etc.), the unit should be maintained by qualified service personnel at regular intervals to prevent overheating and other malfunction.



**NOTICE!**

**Power supply**

Before connecting the device, ensure that the input voltage (AC outlet) matches the voltage rating of the device and that the AC outlet is protected by a residual current circuit breaker. Failure to do so could result in damage to the device and possibly injure the user.

Unplug the device before electrical storms occur and when it is unused for long periods of time to reduce the risk of electric shock or fire.



**NOTICE!**

**Risk of fire due to incorrect polarity**

Incorrectly inserted batteries may destroy the device or the batteries.

Ensure that proper polarity is observed when inserting batteries.



### **NOTICE!**

#### **Possible damage by leaking batteries**

Leaking batteries can cause permanent damage to the device.

Take batteries out of the device if it is not going to be used for a longer period.



### **NOTICE!**

#### **Possible damage due to installation of a wrong fuse**

The use of different types of fuses can cause serious damage to the unit. Fire hazard!

Only fuses of the same type may be used.





**NOTICE!**

**Risk of short-circuits**

Short-circuits may cause irreparable damages of the device. They can occur when you remove or change cables of the spots during operation.

Disconnect the device from the power supply before you change the cabling.



**NOTICE!**

**Damages due to disconnection during operation**

Only operate the unit when all spotlights are connected.

The disconnection of LED spotlights during operation may damage the unit. Disconnect the unit from the power supply before disconnecting LED spotlights.

### 3 Features

The LED lighting set is particularly suitable for lighting applications in clubs and discotheques, on rock stages, in theatres and musicals.

Special features of the device:

- 4 spots with 7 TRI-Colour LEDs each
- Control via DMX (6 different modes), buttons and display on the unit or via remote control (not included, item no. 354223)
- 16 preprogrammed automatic shows
- Sound control
- Master / Slave mode
- Easy transport, easy mounting
- An additional carrying bag is included

For technological reasons, the light output of LEDs decreases over their lifetime. This effect increases with higher operating temperature. You can extend the service life of the illuminants by providing adequate ventilation and operating the LEDs with the lowest possible brightness.

## 4 Installation

Unpack and check carefully there is no transportation damage before using the unit. Keep the equipment packaging. To fully protect the product against vibration, dust and moisture during transportation or storage use the original packaging or your own packaging material suitable for transport or storage, respectively.



### **WARNING!**

#### **Risk of injury caused by falling objects**

Make sure that the installation complies with the standards and rules that apply in your country. Always secure the device with a secondary safety attachment, such as a safety cable or a safety chain.



### **NOTICE!**

#### **Damages due to disconnection during operation**

Only operate the unit when all spotlights are connected.

The disconnection of LED spotlights during operation may damage the unit. Disconnect the unit from the power supply before disconnecting LED spotlights.



### **NOTICE!**

#### **Risk of overheating**

The distance between light output and the illuminated surface must be more than 1.5 m (19.7in).

Provide sufficient ventilation.

The ambient temperature must always be below 40 °C (104 °F).



**NOTICE!**

**Use of stands**

When mounting the device onto a stand, ensure that the stand is in a safe and stable position and that the weight of the device does not exceed the maximum permissible load capacity of the stand.



**NOTICE!**

**Possible data transmission errors**

For error-free operation make use of dedicated DMX cables and do not use ordinary microphone cables.

Never connect the DMX input or output to audio devices such as mixers or amplifiers.

## Pre-mounted spots

The four spots (1 ... 4, right to left) are pre-mounted on the T-bar.

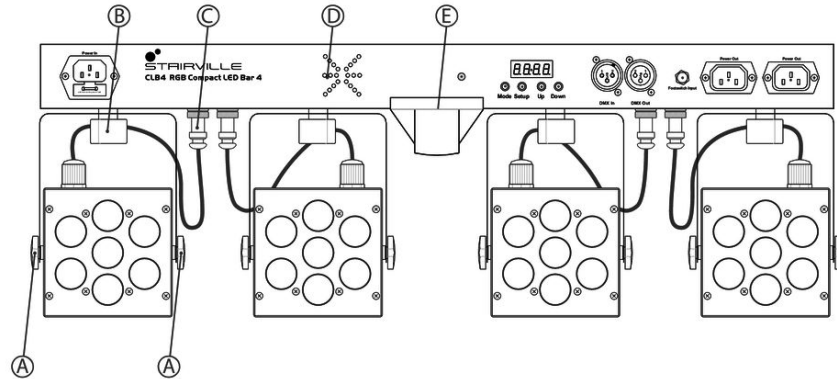

A	Locking screw for fixing the inclination angle.
B	Locking screw for fixing the spots on the T-bar and the horizontal orientation (dispersion direction).
C	Electrical connection of the spot at the T-bar (pre-mounted).

D	1/4" phone socket to connect a foot controller.
E	Flange 36 mm to mount the T-bar on a stand.

### Inserting the battery into the remote control

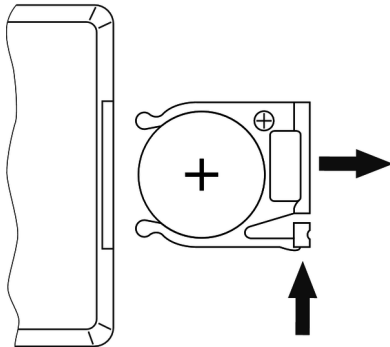

Press the lock of the battery holder to the centre of the housing and pull out the battery holder like a drawer. Insert the battery. The battery is correct if the positive pole points to the housing base of the remote control. Slide the battery holder back into the remote until it clicks into place.

When shipping, the battery is already installed in the remote and protected against discharge by a transparent plastic foil. Remove the plastic foil prior to first use.



*Please note that this device must not be connected to a dimmer.*



## 5 Setup

Create all connections while the device is off. Use the shortest possible high-quality cables for all connections. Take care when running the cables to prevent tripping hazards.

**Connections in DMX mode**

Connect the DMX input of the device to the DMX output of a DMX controller or another DMX device. Connect the output of the first DMX device to the input of the second one, and so on to form a daisy chain. Always ensure that the output of the last DMX device in the daisy chain is terminated with a resistor ( $110\ \Omega$ ,  $\frac{1}{4}\text{ W}$ ).

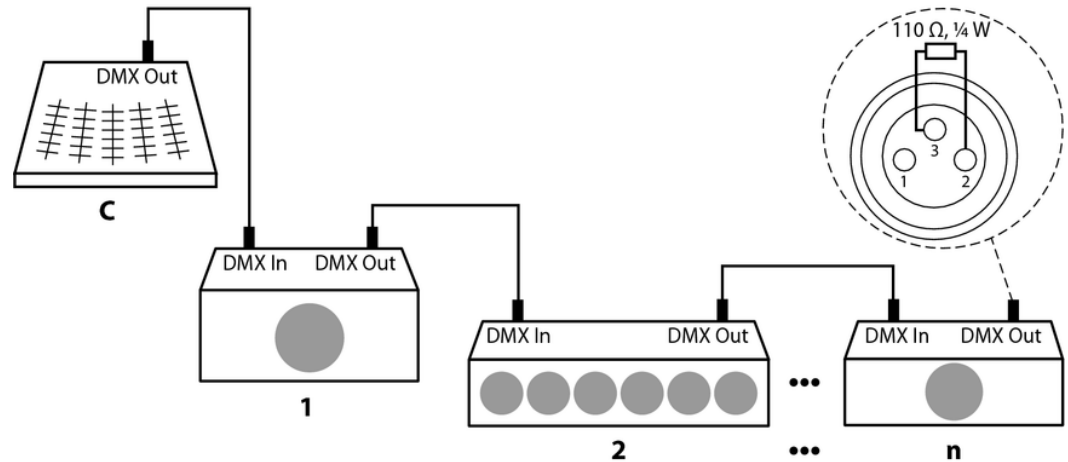

**DMX indicator**

If the dot behind the first character of the display is flashing in the DMX mode, no DMX signal is received. Maybe the DMX controller is not switched on or there is a cabling error. If the indicator lights permanently, the device receives a valid DMX signal.

**Connections in master/slave mode**

When you configure a group of devices in master/slave mode, the first unit will control the other units for an automatic, sound-activated, synchronized show. This function is ideal when you want to start a show immediately. Connect the DMX output of the master device to the DMX input of the first slave device. Then connect the DMX output of the first slave device to the DMX input of the second slave device and so on.

## 6 Connections and controls

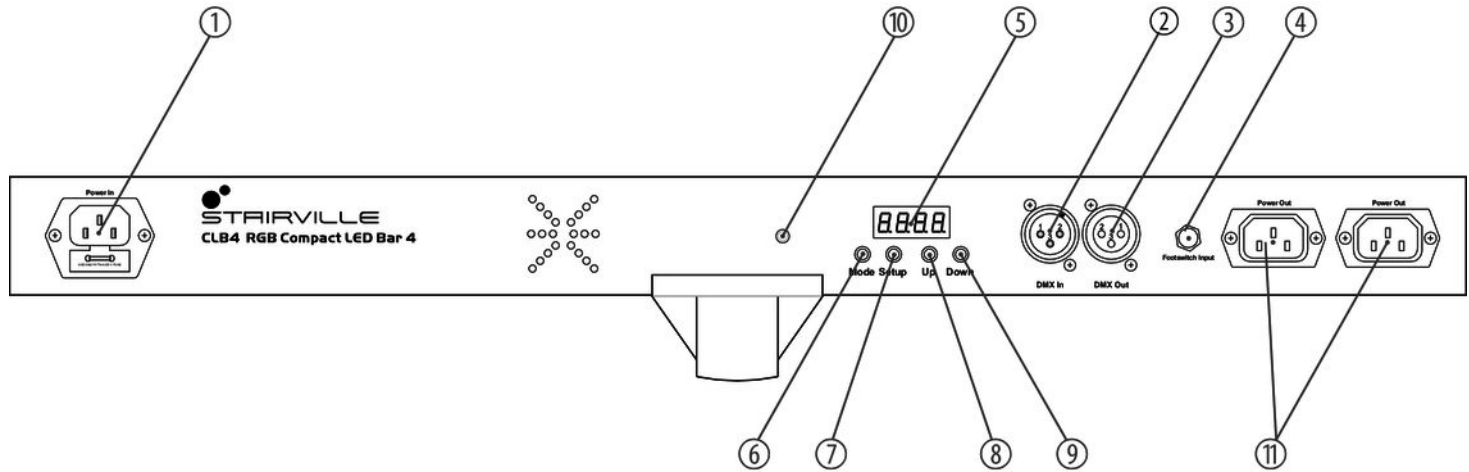

1	<i>[Power In]</i> IEC chassis plug for operating voltage supply with fuse holder.
2	<i>[DMX In]</i> DMX input.
3	<i>[DMX Out]</i> DMX output.
4	<i>[Footswitch Input]</i> 1/4" phone socket to connect a foot controller.
5	Display.
6	<i>[Mode]</i> Activates the main menu and moves between menu items. Closes an opened sub menu.
7	<i>[Setup]</i> Selects an option of the respective operating mode, confirms the set value.

8	<i>[Up]</i> Increases the displayed value by one.
9	<i>[Down]</i> Decreases the displayed value by one.
10	Infra red receiver for the IR remote control signal. Make sure that the receiver is not obstructed.
11	<i>[Power Out]</i> 2 × IEC chassis socket for the power supply cable to the next unit of the same type.

**Remote control**

Remote control not included in delivery (optional accessory).

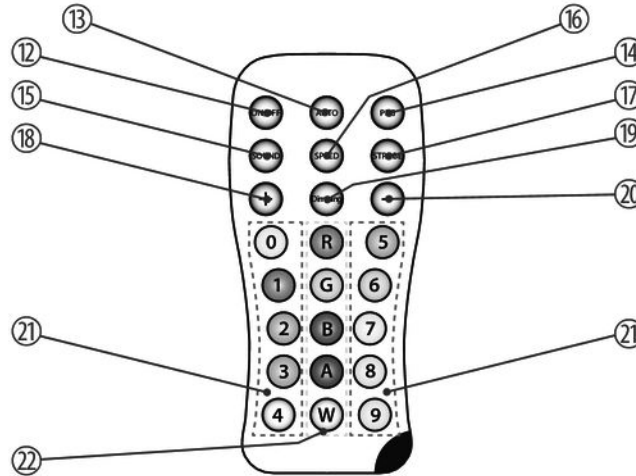

12	<i>[ON/OFF]</i> Button to turn the device on and off.
13	<i>[AUTO]</i> Activates the 'Automatic' mode.
14	<i>[PRG]</i> Activates the operating mode 'Preprogrammed automatic show'.
15	<i>[SOUND]</i> Activates the 'Sound Control' mode.
16	<i>[SPEED]</i> Adjusts the process speed in 'Preprogrammed automatic show' mode.
17	<i>[STROBE]</i> Activates the strobe effect in 'Preprogrammed automatic show' mode.
18	<i>[+]</i> Increases the displayed value by one.



19	<i>[Dimming]</i> Brightness control.
20	<i>[-]</i> Decreases the displayed value by one.
21	<i>[0] ... [9]</i> Numeric keys.
22	Buttons for colour selection. Use <ul style="list-style-type: none"><li>■ <i>[W]</i> for white light,</li><li>■ <i>[A]</i> for amber light,</li><li>■ <i>[R]</i>, <i>[G]</i>, or <i>[B]</i> for primary colours red, green and blue,</li><li>■ the coloured buttons for directly selecting a mixed colour.</li></ul>

## **7 Operation**

### **7.1 Starting up the device**

To start up the device, connect it to the mains.

### **7.2 Device functions**

All functions are controlled via buttons and display on the unit.

### **7.3 Foot switch**

You can also control several device functions using an optional foot switch. Please note the following table for the function assignment.

<b>Auto Run</b>	<p>Press the button repeatedly until the display shows 'AUTO' to activate the 'Automatic' mode (13 programmes run automatically in sequence).</p> <p>Press the switch in a running programme to jump into the next one. If you press the switch in programme 13, the sequence restarts with programme 1.</p>
<b>Sound Active</b>	<p>Press the button once to activate the 'Sound-control' mode.</p> <p>Press the button again to toggle between the 16 available sound modes.</p>
<b>Freeze</b>	<p>Press the button once to pause a running programme.</p> <p>Press the button again to let the programme continue.</p>
<b>Blackout</b>	<p>Press the button once to turn off a running programme.</p> <p>Press the button again to return to the previous mode.</p>

## 7.4 Remote control

If the device neither is working as Slave in a Master / Slave configuration nor is not controlled via DMX you can control it using the remote control.

### Switching on / off

Use *[ON/OFF]* to switch the device on and off.

### Operating mode 'Automatic'

Press *[AUTO]*. The playback of 'Pr02' to 'Pr14' starts automatically.

### Operating mode 'Preprogrammed automatic show'

Press *[PRG]*. Use *[+]* and *[-]* to select a value between 'Pr.01' and 'Pr.14'.

In the 'Preprogrammed automatic show' mode, you can activate the strobe effect. Press *[STROBE]* and use *[+]* and *[-]* to select a value between 'FS00' (slow) and 'FS99' (fast). Press again *[STROBE]* to turn the strobe effect off.

For the programmes 'Pr.01' and 'Pr.09', it is possible to adjust the process speed. Press *[SPEED]* and use *[+]* and *[-]* to select a value between 'SP01' (slow) and 'SPFL' (fast).

### Sound control

Press *[SOUND]*. This activates a sound controlled automatic show.

Use *[+]* and *[-]* to adjust the sensitivity of the sound control in a range from 'SV.00' to 'SV.31'.

### Dimming

Press *[Dimming]* to adjust the brightness level of the primary colours. Press *[R]* (red), *[G]* (green), or *[B]* (blue) and use *[+]* and *[-]* to select a value between 0 and 255.

**Colour selection**

Use the coloured buttons to select a colour tone in any mode. The following assignment applies:

Button	Colour	Button	Colour	Button	Colour
0	Cyan	5	Bright red	R	Red
1	Purple	6	Bright green	G	Green
2	Magenta	7	Bright blue	B	Blue
3	Orange	8	Yellow	A	Amber
4	Cold white	9	Warm white	W	White

**Resetting to factory defaults**

To reset the device, press *[OFF]* and subsequently *[9]*, *[8]*, and *[7]*.

## 7.5 Operating controls on the unit

Press *[Mode]* to activate the main menu and select an operating mode. Use *[Setup]* to select further options. Use *[Up]* and *[Down]* to change the respectively displayed value. When the display shows the desired value, press *[MODE]*.

If you do not press any key for about 30 seconds, the display will be blanked. It will be reactivated to display the previously shown menu by pressing any button.

The set values are retained even when the device is disconnected from the mains power supply.

## Operating mode 'Preprogrammed automatic show'

A preprogrammed automatic show can only be activated when the unit is operating in stand alone mode or as master in a master / slave combination. This setting is only relevant if the device is not controlled via DMX.

Press *[Mode]* repeatedly until the display shows 'Pr.xx'. Now you can select one of the preprogrammed automatic shows. Use *[Up]* and *[Down]* to select a value between 'Pr.01' and 'Pr.14'.

### Settings for programme 01:

For 'Pr.01', you can choose from 14 predefined colours, white or blackout. Press *[Setup]*. Use *[Up]* and *[Down]* to select one of the preprogrammed colours.

To adjust the strobe frequency, press *[Setup]* again. The display shows 'FS00'. Use *[Up]* and *[Down]* to select a value between 'FS00' (slow) and 'FS99' (fast).

### Settings for programmes 02 to 14:

To adjust the programme speed, press again *[Setup]*. The display shows 'SPxx'. Use *[Up]* and *[Down]* to select a value between 'SP01' (slow) and 'SPFL' (fast).

To adjust the strobe frequency, press *[Setup]* again. The display shows 'FS00'. Use *[Up]* and *[Down]* to select a value between 'FS00' (slow) and 'FS99' (fast).

### **Operating mode 'Automatic'**

Automatic operation can only be activated when the unit is operating in stand alone mode or as master in a master / slave combination. This setting is only relevant if the device is not controlled via DMX.

Press *[Mode]* repeatedly until the display shows 'AUTO'. The playback of 'Pr02' to 'Pr14' starts automatically.

To adjust the programme speed, press *[Setup]*. The display shows 'SPxx'. Use *[Up]* and *[Down]* to select a value between 'SP01' (slow) and 'SPFL' (fast).

To adjust the strobe frequency, press *[Setup]* again. The display shows 'FS00'. Use *[Up]* and *[Down]* to select a value between 'FS00' (slow) and 'FS99' (fast).



**DMX mode**

This setting takes effect only when the device is operated under DMX control.

Press *[Mode]* until the display shows 'd.001'.

You can now set the number of the first DMX channel used by the device (DMX address). Use *[Up]* and *[Down]* to select a value between 1 and 512 (display shows 'd.001' ... 'd.512').

Ensure that this channel number fits to the configuration of your DMX controller. The following table shows the highest usable DMX address for the different DMX modes.

Mode	Highest usable DMX address
3 channel	510
4 channels	509
8 channels	505
14 channels	499
2 channels	511
7 channels	506

Press *[Setup]*. Now use *[UP]* and *[DOWN]* to select one of the following DMX operating modes:

- '3-ch' (three channels)
- '4-ch' (four channels)
- '8-ch' (eight channels)
- '14ch' (14 channels)
- '2-ch' (two channels)
- '7-ch' (seven channels)

### **Operating mode 'Slave'**

This setting is only relevant if the device is serving as Slave in a Master / Slave configuration and is not controlled via DMX.

Press *[Mode]* until the display shows 'SLAV'.

## Sound control

A sound controlled automatic show can only be activated when the unit is operating in stand alone mode or as master in a master / slave combination. This setting is only relevant if the device is not controlled via DMX.

Press *[Mode]* repeatedly until the display shows 'SOud'. This activates a sound controlled automatic show.

Press *[Setup]* and use *[Up]* and *[Down]* to activate sound control mode 'SO.01' ... 'SO.16'.

Press *[Setup]* and use *[Up]* and *[Down]* to adjust the sensitivity for the sound control in a range from 'SV.00' to 'SV.31'.

### Constant unicoloured pattern

A constant unicoloured pattern can only be activated when the unit is operating in stand alone mode or as master in a master / slave combination. This setting is only relevant if the device is not controlled via DMX.

Press *[Mode]* until the display shows 'Colr'. Press *[Setup]*. The display shows 'r.xxx', 'G.xxx', or 'b.xxx'. Press *[Setup]* to change the colour.

Use *[Up]* and *[Down]* to adjust the intensity of the colour:

Display	Meaning
'r.000' ... 'r.255'	Red
'G.000' ... 'G.255'	Green
'b.000' ... 'b.255'	Blue

## 7.6 Menu diagram

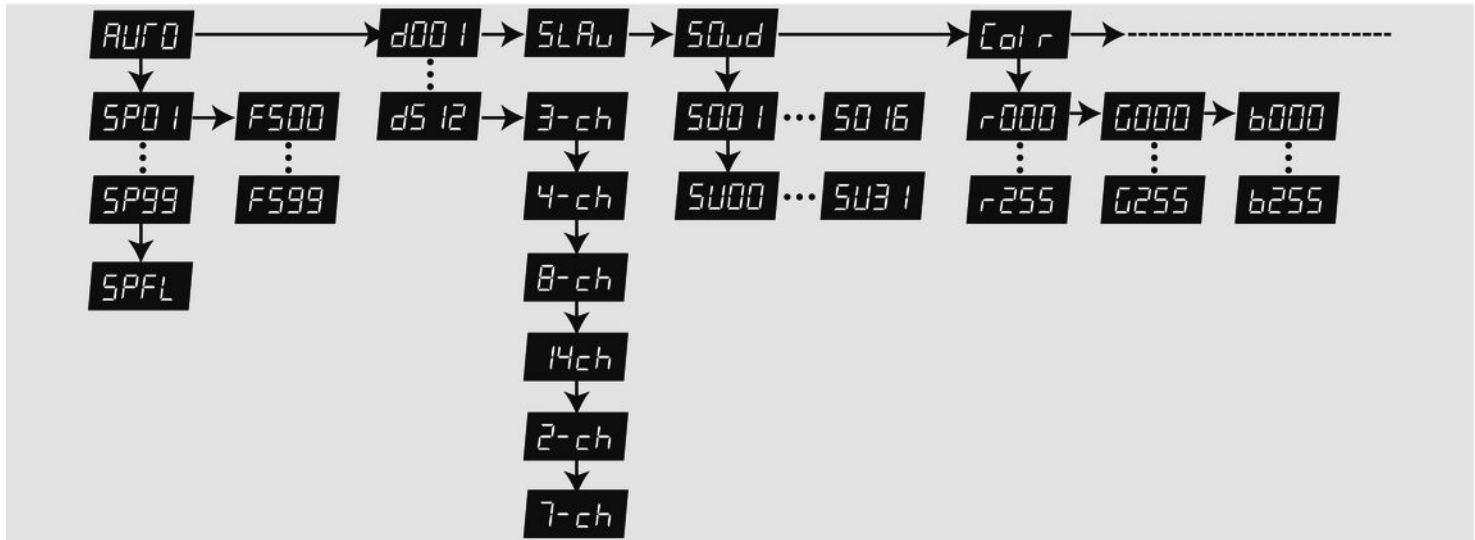

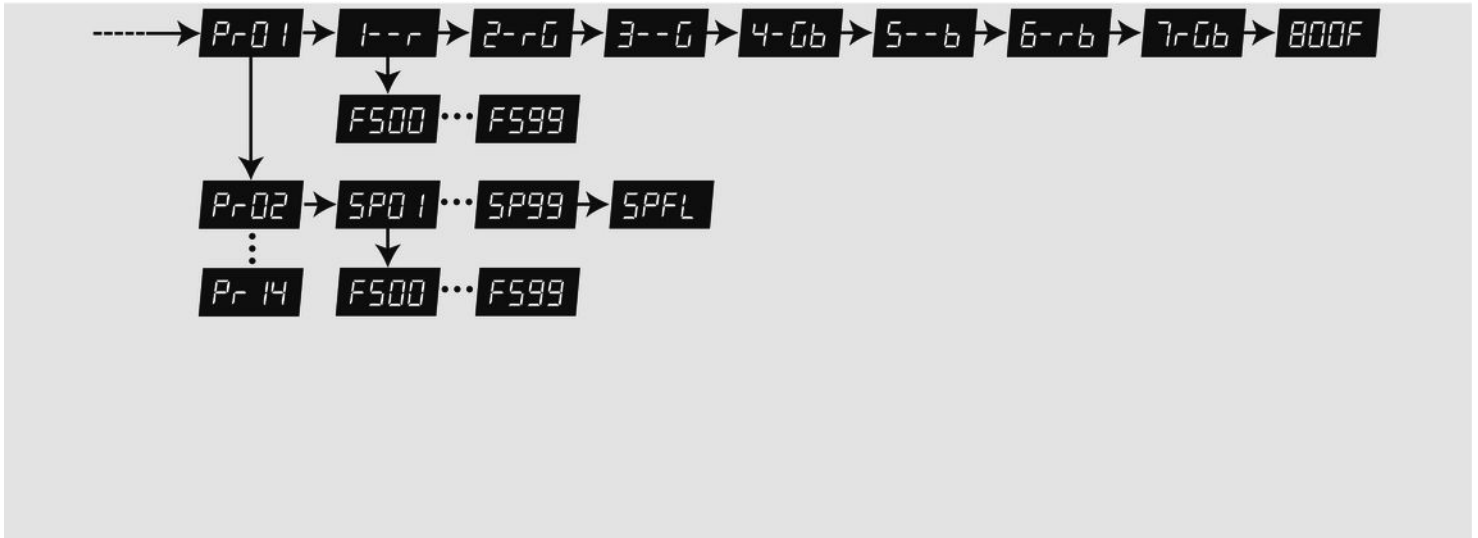

## 7.7 Functions in 2-channel DMX mode

Channel	Value	Function
1	0...9	LEDs off
	10...19	Constant unicoloured pattern in red for all LEDs
	20...29	Constant unicoloured pattern in yellow for all LEDs
	30...39	Constant unicoloured pattern in green for all LEDs
	40...49	Constant unicoloured pattern in cyan for all LEDs
	50...59	Constant unicoloured pattern in blue for all LEDs
	60...69	Constant unicoloured pattern in pink for all LEDs
	70...79	Constant unicoloured pattern in white for all LEDs
	80...89	Preprogrammed automatic show no. 1, speed adjustment via channel 2
		:
	230...239	Preprogrammed automatic show no. 16, speed adjustment via channel 2

Channel	Value	Function
	240...255	Sound-controlled show
2	0...255	Increasing speed
	Channel 1 = 240...225	
	0...255	Sound mode 1...16

## 7.8 Functions in 3-channel DMX mode

Channel	Value	Function
1	0...255	Intensity red (0 % to 100 %), for all LEDs together
2	0...255	Intensity green (0 % to 100 %), for all LEDs together
3	0...255	Intensity blue (0 % to 100 %), for all LEDs together



## 7.9 Functions in 4-channel DMX mode

Channel	Value	Function
1	0...255	Intensity red (0 % to 100 %), for all LEDs together
2	0...255	Intensity green (0 % to 100 %), for all LEDs together
3	0...255	Intensity blue (0 % to 100 %), for all LEDs together
4	0...255	Dimmer (0 % to 100 %)

## 7.10 Functions in 7-channel DMX mode

Channel	Value	Function
1	0...255	Intensity red (0 % to 100 %), for all LEDs together
2	0...255	Intensity green (0 % to 100 %), for all LEDs together
3	0...255	Intensity blue (0 % to 100 %), for all LEDs together

Channel	Value	Function
4	0...9	Manual mode, all colours can be adjusted via channels 1 to 3
	10...19	Constant unicoloured pattern in red for all LEDs
	20...29	Constant unicoloured pattern in yellow for all LEDs
	30...39	Constant unicoloured pattern in green for all LEDs
	40...49	Constant unicoloured pattern in cyan for all LEDs
	50...59	Constant unicoloured pattern in blue for all LEDs
	60...69	Constant unicoloured pattern in pink for all LEDs
	70...79	Constant unicoloured pattern in white for all LEDs
	80...89	Preprogrammed automatic show no. 1
		:
	230...239	Preprogrammed automatic show no. 16
240...255	Sound-controlled show	
5	0...255	Increasing speed

Channel	Value	Function
	Channel 4 = 240...255	
	0...255	Sound mode 1...16
6	Channel 4 = 0...239	
	0...255	Strobe effect, increasing speed
7	Channel 4 = 0...239	
	0...255	Dimmer (0 % to 100 %)

## 7.11 Functions in 8-channel DMX mode

Channel	Value	Function
1	0...255	Intensity red (0 % to 100 %) all LEDs spot 1 and 2
2	0...255	Intensity green (0 % to 100 %) all LEDs spot 1 and 2

Channel	Value	Function
3	0...255	Intensity blue (0 % to 100 %) all LEDs spot 1 and 2
4	0...255	Intensity red (0 % to 100 %) all LEDs spot 3 and 4
5	0...255	Intensity green (0 % to 100 %) all LEDs spot 3 and 4
6	0...255	Intensity blue (0 % to 100 %) all LEDs spot 3 and 4
7	0...255	Strobe effect, increasing speed, all LEDs spot 3 and 4
8	0...255	Dimmer (0 % to 100 %)

### 7.12 Functions in 14-channel DMX mode

Channel	Value	Function
1	0...255	Intensity red (0 % to 100 %) all LEDs spot 1
2	0...255	Intensity green (0 % to 100 %) all LEDs spot 1

Channel	Value	Function
3	0...255	Intensity blue (0 % to 100 %) all LEDs spot 1
4	0...255	Intensity red (0 % to 100 %) all LEDs spot 2
5	0...255	Intensity green (0 % to 100 %) all LEDs spot 2
6	0...255	Intensity blue (0 % to 100 %) all LEDs spot 2
7	0...255	Intensity red (0 % to 100 %) all LEDs spot 3
8	0...255	Intensity green (0 % to 100 %) all LEDs spot 3
9	0...255	Intensity blue (0 % to 100 %) all LEDs spot 3
10	0...255	Intensity red (0 % to 100 %) all LEDs spot 4
11	0...255	Intensity green (0 % to 100 %) all LEDs spot 4
12	0...255	Intensity blue (0 % to 100 %) all LEDs spot 4
13	0...255	Strobe effect, increasing speed
14	0...255	Dimmer (0 % to 100 %)

## 8 Technical specifications

Light source	28 × tri-colour LEDs, 3 W	
Optical properties	Beam angle	45°
Control	DMX	
	Remote control (optional)	
Number of DMX channels	2, 3, 4, 7, 8, 14	
Input connections	Voltage supply	IEC chassis plug C14
	DMX control	XLR chassis socket, 3-pin
	Foot controller unit	1/4" jack socket
Output connections	Voltage supply	IEC chassis plug C13
	DMX control	XLR chassis socket, 3-pin
Power consumption	80 W/240 V	
	82 W/110 V	

Supply voltage	100 – 240 V ~ 50/60 Hz	
Fuse	5 mm × 20 mm, 2 A, 250 V, slow-blow	
Remote control battery	Battery type	Lithium button cell, 3 V, CR 2025
Degree of protection	IP20	
Mounting options	Stand adapter: 36 mm flange	
Dimensions (W × H × D)	682 mm × 60 mm × 270 mm	
Weight	5.4 kg	
Ambient conditions	Temperature range	0 °C...40 °C
	Relative humidity	50 %, non condensing

### Further information

Spotlight included	Yes
Effect devices included	No
LED bars included	No
Control included	No
Stand included	No
Case/bag included	Yes



## 9 Plug and connection assignments

### Introduction

This chapter will help you select the right cables and plugs to connect your valuable equipment so that a perfect light experience is guaranteed.

Please take our tips, because especially in 'Sound & Light' caution is indicated: Even if a plug fits into a socket, the result of an incorrect connection may be a destroyed DMX controller, a short circuit or 'just' a not working light show!

### DMX connections

The unit offers a 3-pin XLR socket for DMX output and a 3-pin XLR plug for DMX input. Please refer to the drawing and table below for the pin assignment of a suitable XLR plug.



Pin	Configuration
1	Ground, shielding
2	Signal inverted (DMX-, 'cold signal')
3	Signal (DMX+, 'hot signal')

## 10 Troubleshooting



### **NOTICE!**

#### **Possible data transmission errors**

For error-free operation make use of dedicated DMX cables and do not use ordinary microphone cables.

Never connect the DMX input or output to audio devices such as mixers or amplifiers.

In the following we list a few common problems that may occur during operation. We give you some suggestions for easy troubleshooting:

Symptom	Remedy
The unit does not work, no light	Check the mains connection and the fuse.
No response to the DMX controller	1. If the dot behind the first character of the display is flashing in the DMX mode, no DMX signal is received. Make sure that the DMX controller is turned on. Check the DMX ports and cables for proper connection.
	2. If the display does not flash and still no response, check the address settings and the DMX polarity.
	3. Try using another DMX controller.
	4. Check to see if the DMX cables run near or alongside to high voltage cables that may cause damage or interference to DMX interface circuits.

If the procedures recommended above do not succeed, please contact our Service Center. You can find the contact information at [www.thomann.de](http://www.thomann.de).

## 11 Cleaning

### Optical lenses

Clean the optical lenses, that are accessible from the outside, regularly in order to optimize the light output. The frequency of cleaning depends on the operating environment: wet, smoky or particularly dirty surroundings can cause more accumulation of dirt on the optics of the device.

- Clean with a soft cloth using our lamp and lens cleaner (item no. 280122).
- Always dry the parts carefully.

## 12 Protecting the environment

### Disposal of the packaging material



For the transport and protective packaging, environmentally friendly materials have been chosen that can be supplied to normal recycling.

Ensure that plastic bags, packaging, etc. are properly disposed of.

Do not just dispose of these materials with your normal household waste, but make sure that they are fed to a recovery. Please follow the notes and markings on the packaging.

### Disposal of batteries



Batteries must not be disposed of as domestic waste or thrown into fire. Dispose of the batteries according to national or local regulations regarding hazardous waste. To protect the environment, dispose of empty batteries at your retail store or at appropriate collection sites.

### Disposal of your old device



This product is subject to the European Waste Electrical and Electronic Equipment Directive (WEEE) in its currently valid version. Do not dispose with your normal household waste.

Dispose this device through an approved waste disposal firm or through your local waste facility. When discarding the device, comply with the rules and regulations that apply in your country. If in doubt, consult your local waste disposal facility.



Musikhaus Thomann · Hans-Thomann-Straße 1 · 96138 Burgebrach · Germany · [www.thomann.de](http://www.thomann.de)