

8NMB420

High Output Midbass Neo Transducer

Key Features

- 95 dB SPL 1W / 1m average sensitivity
- 51mm (2 in) Interleaved Sandwich Voice coil (ISV)
- 280 W AES power handling
- External neodymium magnet assembly
- Single Demodulating Ring (SDR) for lower distortion
- Weather protected cone and plates for outdoor usage
- Suitable for line arrays and compact two way systems



General Description

The 8NMB420 neodymium transducer has been developed in response to a specific market requirement for a 8" midbass driver that combines excellent linearity with good efficiency and high power handling capabilities.

8NMB420 is primarily intended for use as a midbass driver in compact 2-way or multiway reflex enclosures comprising line arrays. The parameters had been chosen to offer significant low frequency output in vented enclosure with size starting from 20 lit. with a tuning frequency around 60Hz. The low pass filter might be positioned as high as 2000-2500Hz. Multiple 8NMB420 units might be used: the compact size reflects in the capability to have precise attack time. This characteristic makes it the ideal choice for stage monitoring and bass guitar amplification.

The extremely powerful external neodymium magnet assembly assures high flux concentration, low power compression and excellent heat exchange. The levels of force factor and power handling are, as a consequence, at the upper professional level with best power to weight ratio.

The exclusive dedicated double roll surround design offers enhanced linear travel and control, in order to reproduce precisely low frequency. The curvilinear paper cone is formed using a unique wood pulp composition designed to achieve the best possible rigidity and stiffness.

The 50mm inside outside aluminum voice coil employs Interleaved Sandwich Voice coil (ISV) technology. It is composed by a high strength fiberglass former used to carry windings on both the outer and inner surfaces to achieve a mass balanced coil. This results in an extremely linear motor assembly which, in conjunction with the highly advanced design of the magnetic structure, provides a high force factor or BL. The voice coil is cooled incorporating airways between the chassis back plate and the magnet faceplate so that heated air is channeled away from the voice coil and gap and dissipated by the chassis basket.

Thanks to the increasing use during outdoor audio events, the ability to perform in humid environments is a key feature of the 8NMB420. This is achieved through a proprietary humidity repellent cone treatment without a moving speaker mass increase.

022088N400 8ohm
022086N400 16ohm
022084N400 4ohm

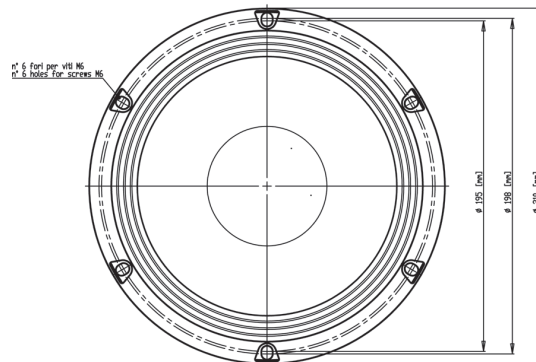
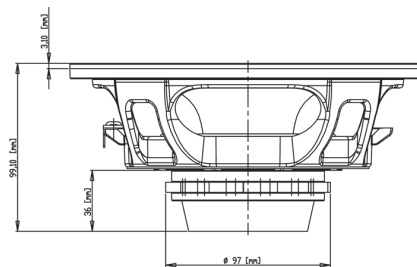

NEODYMIUM LF-MB-MF TRANSDUCERS

8NMB420

High Output Midbass Neo Transducer

GENERAL SPECIFICATIONS

| | |
|-------------------------------|--------------------------------|
| NOMINAL DIAMETER | 200mm (8 in) |
| RATED IMPEDANCE | 8 Ohm |
| AES POWER | 280 W |
| PROGRAM POWER (1) | 400 W |
| PEAK POWER (2) | 800 W |
| SENSITIVITY (3) | 95 dB |
| FREQUENCY RANGE (4) | 60 ÷ 5500 Hz |
| POWER COMPRESSION @-10DB (5) | 0,8 dB |
| POWER COMPRESSION @-3DB | 1,7 dB |
| POWER COMPRESSION @FULL POWER | 2,2 dB |
| MAX RECOMM. FREQUENCY | 2500 Hz |
| RECOMM. ENCLOSURE VOLUME | 10 ÷ 40 lt. (0,35 ÷ 1,41 cuft) |
| MINIMUM IMPEDANCE | 5,90hm at 25°C |
| MAX PEAK TO PEAK EXCURSION | 19 mm (0,7 in) |
| VOICE COIL DIAMETER | 51 mm (2 in) |
| VOICE COIL WINDING MATERIAL | aluminum |
| SUSPENSION | M-roll, Polycotton |
| CONE | Curvilinear, Treated paper |

THIELE SMALL PARAMETERS (6)

| | |
|------------------------------------|----------------------------|
| Fs | 61 Hz |
| Re | 5 Ohm |
| Sd | 0,022 sq.mt. (34,1 sq.in.) |
| Qms | 4 |
| Qes | 0,31 |
| Qts | 0,28 |
| Vas | 33 lt. (1,2cuft) |
| Mms | 14,9 gr. (32,9 lb) |
| BL | 10 Tm |
| Linear Mathematical Xmax (7) | ± 5,75 mm (±0,23 in) |
| Le (1kHz) | 0,35 mH |
| Ref. Efficiency 1W@1m (half space) | 95,6dB |

MOUNTING INFORMATIONS

| | |
|--------------------------------|--|
| Overall diameter | 210 mm (8,3 in) |
| N. of mounting holes | 6 |
| Mounting holes diameter | 6 mm (0,23 in) |
| Bolt circle diameter | 195-198 mm (7,68-7,8 in) |
| Front mount baffle cutout ø | 186 mm (7,3 in) |
| Rear mount baffle cutout ø | 184 mm (7,2 in) |
| Total depth | 99 mm (3.9 in) |
| Flange and gasket thickness | 14,5 mm (0,6 in) |
| Net weight | 1,7 kg (3,7 lb) |
| Shipping weight | 2,0 kg (4,4 lb) |
| CardBoard Packaging dimensions | 235 x 235 x 150 mm (9,25 x 9,25 x 5,91 in) |

FREQUENCY RESPONSE CURVE OF 8NMB420 MADE ON 25LIT. ENCLOSURE TUNED 65HZ IN FREE FIELD (4PI) ENVIRONMENT. ENCLOSURE CLOSES THE REAR OF THE DRIVER. THE THIN LINE REPRESENTS 45 DEG. OFF AXIS FREQUENCY RESPONSE

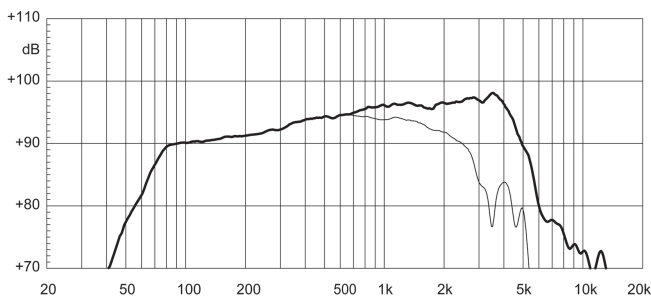

FREE AIR IMPEDANCE MAGNITUDE CURVE

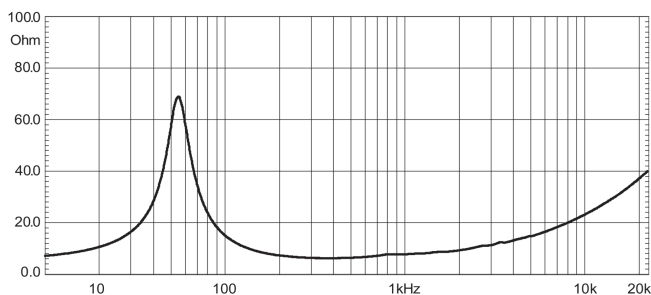

NOTES

- (1) Program power rating is measured in 25 lit enclosure tuned 65Hz using a 60 - 2000 Hz band limited pink noise test signal with 50% duty cycle, applied for 2 hours.
- (2) The peak power rating represents the maximum permitted instantaneous peak power level over a maximum period of 10ms which will be withstood by the loudspeaker without damage.
- (3) Sensitivity represents the averaged value of acoustic output as measured on the forward central axis of cone, at distance 1m from the baffle panel, when connected to 2,83V sine wave test signal swept between 500Hz and 2500Hz with the test specimen mounted in the same enclosure as given for (1) above.
- (4) Frequency range is given as the band of frequencies delineated by the lower and upper limits where the output level drops by 10 dB below the rated sensitivity in half space environment.
- (5) Power compression represents the loss of sensitivity for the specified power, measured from 100-1000 Hz, after a 5 min pink noise preconditioning test at the specified power.
- (6) Thiele - Small parameters are measured after the test specimen has been conditioned by 280 W AES power and represent the expected long term parameters after a short period of use.
- (7) Linear Math. Xmax is calculated as $(Hvc-Hg)/2 + Hg/4$ where Hvc is the coil depth and Hg is the gap depth.

Eighteen Sound engages in research and product improvement. New materials and design refinements can be introduced into existing products without notice.

