



STAIRVILLE

Beam Ball 100 Quad LED
Beam Ball 100 White LED
moving head

Musikhaus Thomann
Thomann GmbH
Hans-Thomann-Straße 1
96138 Burgebrach
Germany
Telephone: +49 (0) 9546 9223-0
E-mail: info@thomann.de
Internet: www.thomann.de

18.11.2019, ID: 400480, 400502 (V4)

Table of contents

1	General information	5
	1.1 Further information.....	6
	1.2 Notational conventions.....	7
	1.3 Symbols and signal words.....	7
2	Safety	10
3	Features	18
4	Installation	20
5	Starting up	24
6	Connections and controls	26
7	Operating	29
	7.1 Starting the device.....	29
	7.2 Main menu.....	30
	7.3 Menu overview.....	38
	7.4 Features in 7-channel DMX mode, BeamBall 100 Quad LED.....	40
	7.5 Features in 11-channel DMX mode, BeamBall 100 Quad LED.....	43

7.6	Features in 15-channel DMX mode, BeamBall 100 Quad LED.....	46
7.7	Features in 49-channel DMX mode, BeamBall 100 Quad LED.....	49
7.8	Features in 8-channel DMX mode, BeamBall 100 White LED.....	53
7.9	Features in 19-channel DMX mode, BeamBall 100 White LED.....	55
8	Technical specifications.....	58
9	Plug and connection assignment.....	61
10	Troubleshooting.....	62
11	Cleaning.....	64
12	Protecting the environment.....	65

1 General information

This user manual contains important information on the safe operation of the device. Read and follow all safety notes and all instructions. Save this manual for future reference. Make sure that it is available to all persons using this device. If you sell the device to another user, be sure that they also receive this manual.

Our products and user manuals are subject to a process of continuous development. We therefore reserve the right to make changes without notice. Please refer to the latest version of the user manual which is ready for download under www.thomann.de.

1.1 Further information

On our website (www.thomann.de) you will find lots of further information and details on the following points:

Download	This manual is also available as PDF file for you to download.
Keyword search	Use the search function in the electronic version to find the topics of interest for you quickly.
Online guides	Our online guides provide detailed information on technical basics and terms.
Personal consultation	For personal consultation please contact our technical hotline.
Service	If you have any problems with the device the customer service will gladly assist you.

1.2 Notational conventions

This manual uses the following notational conventions:

Letterings

The letterings for connectors and controls are marked by square brackets and italics.

Examples: *[VOLUME]* control, *[Mono]* button.

Displays





Texts and values displayed on the device are marked by quotation marks and italics.

Examples: *'24ch'*, *'OFF'*.

1.3 Symbols and signal words

In this section you will find an overview of the meaning of symbols and signal words that are used in this manual.

Signal word	Meaning
DANGER!	This combination of symbol and signal word indicates an immediate dangerous situation that will result in death or serious injury if it is not avoided.
WARNING!	This combination of symbol and signal word indicates a possible dangerous situation that can result in death or serious injury if it is not avoided.
CAUTION!	This combination of symbol and signal word indicates a possible dangerous situation that can result in minor injury if it is not avoided.
NOTICE!	This combination of symbol and signal word indicates a possible dangerous situation that can result in material and environmental damage if it is not avoided.
Warning signs	Type of danger
	Warning – high-voltage.

Warning signs	Type of danger
	Warning – hot surface.
	Warning – dangerous optical radiation.
	Warning – suspended load.
	Warning – danger zone.

2 Safety

Intended use

This device is intended for use as a freely moving multifunctional spotlight. The device is designed for professional use and is not suitable for use in households. Use the device only as described in this user manual. Any other use or use under other operating conditions is considered to be improper and may result in personal injury or property damage. No liability will be assumed for damages resulting from improper use.

This device may be used only by persons with sufficient physical, sensorial, and intellectual abilities and having corresponding knowledge and experience. Other persons may use this device only if they are supervised or instructed by a person who is responsible for their safety.

Extend the operating life of the device by regular breaks and by avoiding frequent switching on and off. The device is not suitable for continuous operation.

Safety

**DANGER!****Danger for children**

Ensure that plastic bags, packaging, etc. are disposed of properly and are not within reach of babies and young children. Choking hazard!

Ensure that children do not detach any small parts (e.g. knobs or the like) from the unit. They could swallow the pieces and choke!

Never let children unattended use electrical devices.

**DANGER!****Electric shock caused by high voltages inside**

Within the device there are areas where high voltages may be present.

Completely disconnect the device from the power supply before you open or remove covers. Mount all covers and attach them firmly before connecting the device again.

Do not use the device if covers, protectors or optical components are missing or damaged.



DANGER!

Electric shock caused by short-circuit

Always use proper ready-made insulated mains cabling (power cord) with a protective contact plug. Do not modify the mains cable or the plug. Failure to do so could result in electric shock/death or fire. If in doubt, seek advice from a registered electrician.



WARNING!

Eye damage caused by high light intensity

Never look directly into the light source.



WARNING!

Risk of epileptic shock

Strobe lighting can trigger seizures in photosensitive epilepsy. Sensitive persons should avoid looking at strobe lights.



WARNING!

Risk of burns

The surface of the device can become very hot during operation.

Do not touch the device with bare hands during operation, and after switching off wait for at least 15 minutes.



WARNING!

Risk of injury caused by falling objects

Make sure that the installation complies with the standards and rules that apply in your country. Always secure the device with a secondary safety attachment, such as a safety cable or a safety chain.



CAUTION!

Risk of injury due to movements of the device

The head of the device can move quickly (pan, tilt) and can produce very bright light. This is also valid immediately after you turn on the device, when the device operates in automatic mode or under remote control and when you turn off a DMX controller that is connected to the device. Persons staying near the device could be injured or frightened.

Before you turn on the device and during the operation, always ensure that nobody stays close to the device. If work has to be performed in the area of movement or in the near vicinity of the device, it must remain turned off.



NOTICE!

Risk of fire

Do not block areas of ventilation. Do not install the device near any direct heat source. Keep the device away from naked flames.

**NOTICE!****Operating conditions**

This device has been designed for indoor use only. To prevent damage, never expose the device to any liquid or moisture. Avoid direct sunlight, heavy dirt, and strong vibrations.

Only operate the device within the ambient conditions specified in the chapter 'Technical specifications' of this user manual. Avoid heavy temperature fluctuations and do not switch the device on immediately after it was exposed to temperature fluctuations (for example after transport at low outside temperatures).

Dust and dirt inside can damage the unit. When operated in harmful ambient conditions (dust, smoke, nicotine, fog, etc.), the unit should be maintained by qualified service personnel at regular intervals to prevent overheating and other malfunction.

The device must not be moved during use.



NOTICE!

Power supply

Before connecting the device, ensure that the input voltage (AC outlet) matches the voltage rating of the device and that the AC outlet is protected by a residual current circuit breaker. Failure to do so could result in damage to the device and possibly injure the user.

Unplug the device before electrical storms occur and when it is unused for long periods of time to reduce the risk of electric shock or fire.



NOTICE!

Possible damage due to installation of a wrong fuse

The use of different types of fuses can cause serious damage to the unit. Fire hazard!

Only fuses of the same type may be used.



NOTICE!

Possible staining

The plasticiser contained in the rubber feet of this product may possibly react with the coating of your parquet, linoleum, laminate or PVC floor and after some time cause permanent dark stains.

In case of doubt, do not put the rubber feet directly on the floor, but use felt-pad floor protectors or a carpet.

3 Features

The moving heads are suitable for lighting tasks in all show areas, for example at events, on club and rock stages, in theatres, musicals and nightclubs.

Beam Ball 100 Quad LED

- 10 × 10 Watt Quad Color RGBW LED
- Control via DMX (7, 11, 15 or 49 channels) and via buttons and display on the unit
- Operating modes: DMX, Auto, Sound, Master / Slave
- Beam angle: 4° ... 11°
- PAN movement: 540°
- TILT movement: infinite
- PAN / TILT speed adjustable
- Dimmer and Strobe function

Beam Ball 100 White LED

- 10 × 10 Watt white light-LED, 7000 K
- Control via DMX (8 or 19 channels) and via buttons and display on the unit
- Operating modes: DMX, Auto, Sound, Master / Slave
- Beam angle: 4° ... 11°

- PAN movement: 540°
- TILT movement: infinite
- PAN / TILT speed adjustable
- Dimmer and Strobe function

For technological reasons, the light output of LEDs decreases over their lifetime. This effect increases with higher operating temperature. You can extend the service life of the illuminants by providing adequate ventilation and operating the LEDs with the lowest possible brightness.

4 Installation

Unpack and check carefully there is no transportation damage before using the unit. Keep the equipment packaging. To fully protect the product against vibration, dust and moisture during transportation or storage use the original packaging or your own packaging material suitable for transport or storage, respectively.

Lift the device only at the base. When lifted at the rotatable mounting, the device may be damaged.

You can install the device standing or hanging. When in use, the device must be mounted at a solid surface or clamped to an approved truss.

Work from a stable platform whenever you install or move the device or when you perform any kind of maintenance. Block access under the work area.

**WARNING!****Risk of injury caused by falling objects**

Make sure that the installation complies with the standards and rules that apply in your country. Always secure the device with a secondary safety attachment, such as a safety cable or a safety chain.

The load capacity of trusses or other fixtures must be sufficient for the intended number of devices. Note that the movement of the head places additional loads on the load-bearing parts.



CAUTION!

Risk of injury due to movements of the device

The head of the device can move quickly (pan, tilt) and can produce very bright light. This is also valid immediately after you turn on the device, when the device operates in automatic mode or under remote control and when you turn off a DMX controller that is connected to the device. Persons staying near the device could be injured or frightened.

Before you turn on the device and during the operation, always ensure that nobody stays close to the device. If work has to be performed in the area of movement or in the near vicinity of the device, it must remain turned off.



NOTICE!

Risk of overheating

The distance between light output and the illuminated surface must be more than 1.5 m (19.7in).

Provide sufficient ventilation.

The ambient temperature must always be below 40 °C (104 °F).

**NOTICE!****Possible damage caused by movements of the device**

Always ensure that enough space is free around the device for the movements of the head (pan, tilt).

**NOTICE!****Possible data transmission errors**

For error-free operation make use of dedicated DMX cables and do not use ordinary microphone cables.

Never connect the DMX input or output to audio devices such as mixers or amplifiers.

Mounting options

The threads on the underside of the housing are used for secure attachment of the device with suitable tools on a truss or the like.

5 Starting up

Create all connections while the device is off. Use the shortest possible high-quality cables for all connections. Take care when running the cables to prevent tripping hazards.

Connections in DMX mode

Connect the DMX input of the device to the DMX output of a DMX controller or another DMX device. Connect the output of the first DMX device to the input of the second one, and so on to form a daisy chain. Always ensure that the output of the last DMX device in the daisy chain is terminated with a resistor ($110\ \Omega$, $\frac{1}{4}\ \text{W}$).

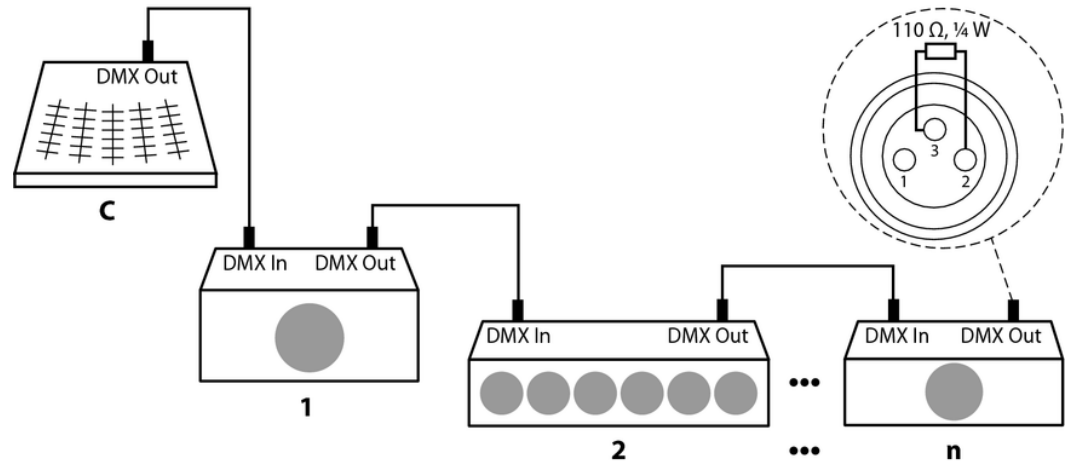

6 Connections and controls

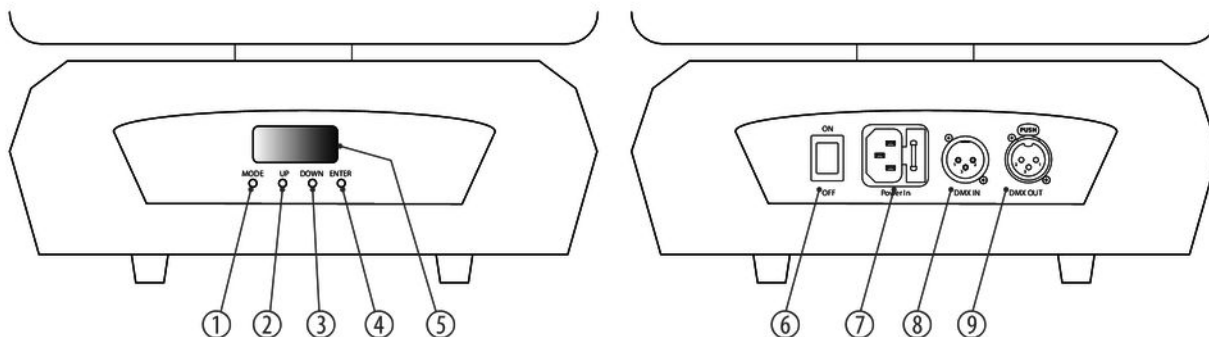

1	<i>[MODE]</i> Activates the main menu and toggles between menu items. Closes an opened submenu.
2	<i>[UP]</i> Increases the displayed value by one.
3	<i>[DOWN]</i> Decreases the displayed value by one.
4	<i>[ENTER]</i> Selects an option of the respective operating mode, confirms the set value.
5	Display
6	<i>[ON] / [OFF]</i> Main switch to turn the device on and off.
7	<i>[POWER IN]</i> IEC chassis connector with fuse holder for the power supply of the device.

8	<i>[DMX IN]</i> DMX input socket (3-pin)
9	<i>[DMX OUT]</i> DMX output socket (3-pin)

7 Operating

7.1 Starting the device



CAUTION!

Risk of injury due to movements of the device

The head of the device can move quickly (pan, tilt) and can produce very bright light. This is also valid immediately after you turn on the device, when the device operates in automatic mode or under remote control and when you turn off a DMX controller that is connected to the device. Persons staying near the device could be injured or frightened.

Before you turn on the device and during the operation, always ensure that nobody stays close to the device. If work has to be performed in the area of movement or in the near vicinity of the device, it must remain turned off.

Connect the device to the mains and switch it on with the main switch. In this mode, the device performs a short self test. The display shows 'F500'.

7.2 Main menu

Press *[MODE]* to activate the main menu. Use the buttons *[UP]* and *[DOWN]* to select a style. When the display shows the desired submenu, press *[ENTER]*, to open it. To close the main menu, press *[MODE]*.

DMX address

Press *[MODE]* to open the main menu. Then choose with *[UP]* or *[DOWN]* the menu item 'DMX'. Press *[MODE]*. Choose with *[UP]* or *[DOWN]* the option 'DMX Addr:' and choose *[UP]* or *[DOWN]* a value between 1 and 512.

Once the display shows the desired option, press the *[ENTER]* button to confirm your setting and to close the menu.

Make sure that the DMX address matches the configuration of your DMX controller.

DMX-Mode, Beam Ball 100 Quad LED

Press *[MODE]* to open the main menu. Then choose with *[UP]* or *[DOWN]* the menu item 'DMX'. Press *[MODE]*. Choose with *[UP]* or *[DOWN]* the option 'DMX Addr:' and choose *[UP]* or *[DOWN]* a value between 1 and 512. '7' (7-channel mode), '11' (11-channel mode), '15' (15-channel mode) or '49' (49-channel mode).

Once the display shows the desired option, press the *[ENTER]* button to confirm your setting and to close the menu.

DMX-Mode, Beam Ball 100 Quad LED

Press *[MODE]* to open the main menu. Then choose with *[UP]* or *[DOWN]* the menu item 'DMX'. Press *[MODE]*. Choose with *[UP]* or *[DOWN]* the option 'DMX Addr:' and choose *[UP]* or *[DOWN]* a value between 1 and 512. '8' (8-channel mode) or '19' (19-channel mode)).

Once the display shows the desired option, press the *[ENTER]* button to confirm your setting and to close the menu.

DMX break

Press *[MODE]* to open the main menu. Then choose with *[UP]* or *[DOWN]* the menu item 'DMX'. Press *[MODE]*. Choose with *[UP]* or *[DOWN]* the option 'DMX Addr:' and choose *[UP]* or *[DOWN]* a value between 1 and 512.

- 'Stop' (turn off device)
- 'Hold' (stop device)
- 'Auto' (change to auto mode)
- 'Sound' (change to sound mode)

Once the display shows the desired option, press the *[ENTER]* button to confirm your setting and to close the menu.

Beam Ball 100 Quad LED

In this menu, you can set various settings for scenes.

Press *[MODE]* to open the main menu. Then choose with *[UP]* or *[DOWN]* the menu item '*DMX*'. Press *[MODE]*. Choose with *[UP]* or *[DOWN]* subsequently the following options and change the configuration values with *[UP]* or *[DOWN]* as desired.

- '*Dimmer*'
- '*PanMSB*'
- '*PanLSB*'
- '*PanSPD*'
- '*TiltMSB*'
- '*TiltLSB*'
- '*TiltSPD*'
- '*Strobe*'
- '*Red*'
- '*Green*'
- '*Blue*'
- '*White*'

Once the display shows the desired option, press the *[ENTER]* button to confirm your setting and to close the menu.

Beam Ball 100 Quad LED

In this menu, you can set various settings for scenes.

Press *[MODE]* to open the main menu. Then choose with *[UP]* or *[DOWN]* the menu item 'DMX'. Press *[MODE]*. Choose with *[UP]* or *[DOWN]* subsequently the following options and change the configuration values with *[UP]* or *[DOWN]* as desired.

- 'Dimmer'
- 'PanMSB'
- 'PanLSB'
- 'PanSPD'
- 'TiltMSB'
- 'TiltLSB'
- 'TiltSPD'
- 'Strobe'
- 'White'

Once the display shows the desired option, press the *[ENTER]* button to confirm your setting and to close the menu.

Menu Bank

In this menu, you can set various settings for the programs.

Press *[MODE]* to open the main menu. Then choose with *[UP]* or *[DOWN]* the menu item '*DMX*'. Press *[MODE]*. Choose with *[UP]* or *[DOWN]* subsequently the following options and change the configuration values with *[UP]* or *[DOWN]* as desired.

- '*Speed*'
- '*Dimmer*'
- '*Strobe*'

Once the display shows the desired option, press the *[ENTER]* button to confirm your setting and to close the menu.

Menu SETTINGS

In this menu, you can configure various settings of the device and reset the device to factory default settings.

Press *[MODE]* to open the main menu. Then choose with *[UP]* or *[DOWN]* the menu item *'DMX'*. Press *[MODE]*. Choose with *[UP]* or *[DOWN]* subsequently the following options and change the configuration values with *[UP]* or *[DOWN]* as desired.

- *'Reload Default'* (reset device to factory settings)
 - *'On'*
 - *'Off'*
- *'Reset Machine'* (restart firmware)
 - *'On'*
 - *'Off'*
- *'Master & Alone'* (Master-/Slave-, Stand-Alone)
 - *'Master'*
 - *'Alone'*
- *'Auto & Sound'* (Auto-, sound-controlled operation)
 - *'Auto'*
 - *'Sound'*
- *'MICSense'* (Sensitivity of the built-in microphone)
- *'Clear Display'* (Display shutdown)
 - *'Always On'*

- *'Delay Off'*
- *'Key Lock'* (code-lock)
 - *'On'* (Code lock is activated 30 seconds after the last key press) To release, press [MODE], [UP], [DOWN] and [ENTER])
 - *'Off'*
- *'Information'*
 - *'LED'*
- *'Date:'* (Date in the format mm.dd.yyyy)
- *'Time:'* (Time in the format hh: mm: ss)
- *'Machine Timer'* (machine time)
 - *'ThisTime'* (current runtime)
 - *'TotlTime'* (totalruntime)
 - *'Clear Total'* (reset, password 001)
- *'Motor Set'*
 - *'Feed Back'* (follow-up movement)
- *'Move Blackout'* (blackout)
 - *'On'*
 - *'Off'*
- *'Motor Calibrate'* (motor settings, password 001)
 - *'Pan Motor'*

- *'Reverse'* (Reverse)
- *'Tilt Motor'*
- *'Record Scene'* (record)
 - *'Red'* (only Beam Ball 100 Quad LED)
 - *'Green'* (only Beam Ball 100 Quad LED)
 - *'Blue'* (only Beam Ball 100 Quad LED)
 - *'White'*
 - *'Yellow'* (only Beam Ball 100 Quad LED)
 - *'Cyan'* (only Beam Ball 100 Quad LED)
 - *'Purple'* (only Beam Ball 100 Quad LED)
 - *'AllWhite'* (only Beam Ball 100 Quad LED)
- *'Advanced Menu'* (enhanced)
 - *'Warning'*
 - *'Password manage'*
 - *'Register'*

Once the display shows the desired option, press the *[ENTER]* button to confirm your setting and to close the menu.

7.3 Menu overview

Beam Ball 100 Quad LED

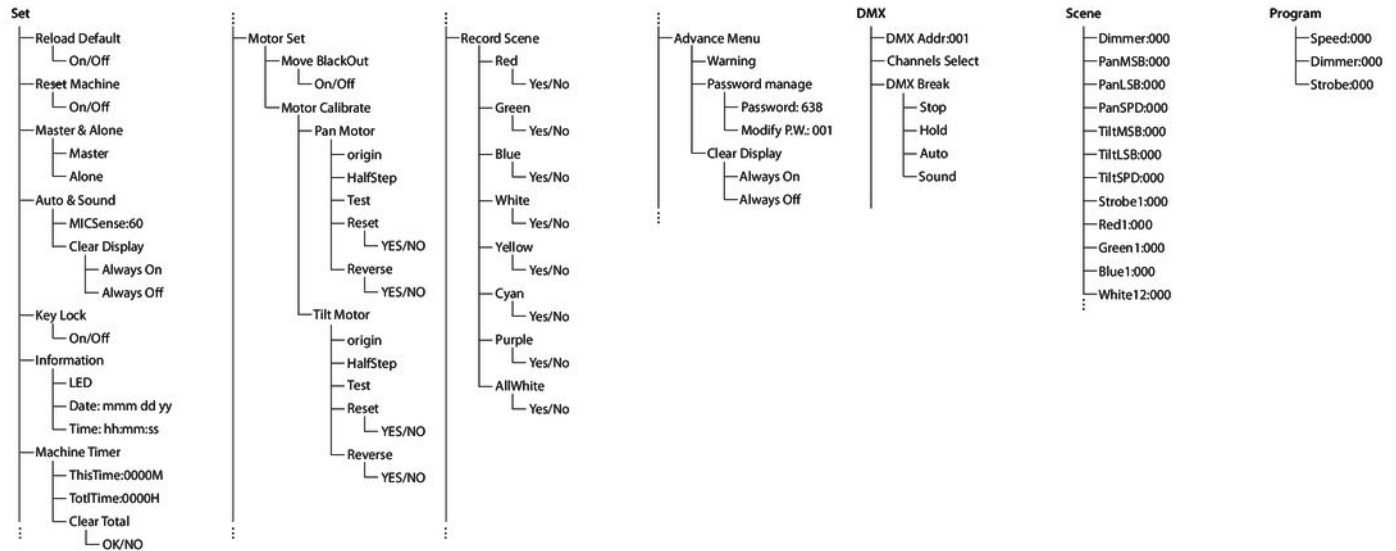

Beam Ball 100 White LED

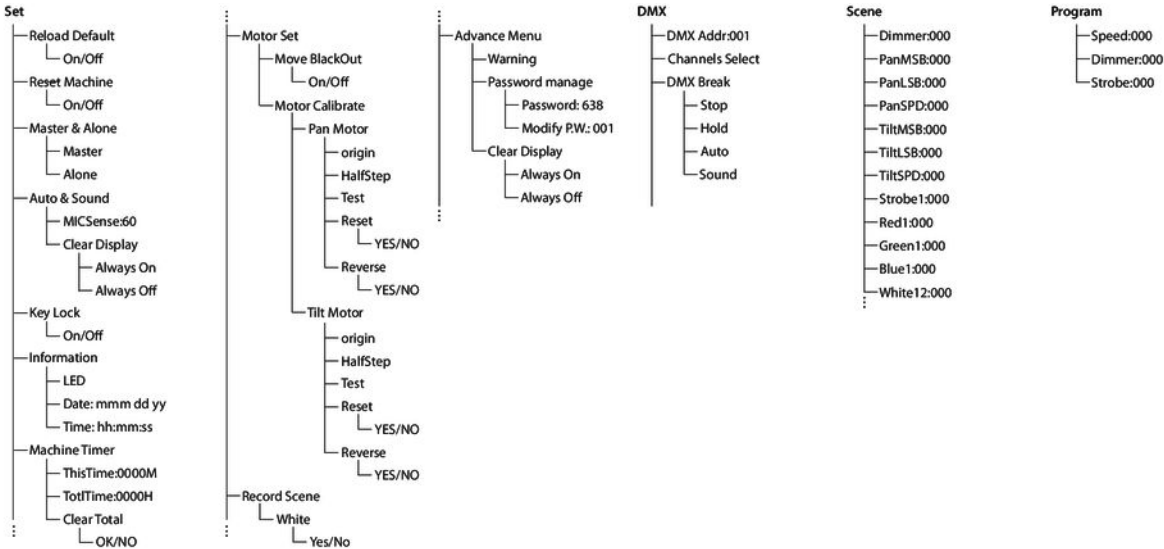

Beam Ball 100 Quad LED Beam Ball 100 White LED

7.4 Features in 7-channel DMX mode, BeamBall 100 Quad LED

Channel	Value	Function
1	0 ... 255	Rotation (Pan)
2	Inclination (tilt)	
	0 ... 191	Fixed position
	192 ... 222	Endless rotation in positive direction, from fast to slow.
	223 ... 224	Stop
	225 ... 255	Endless rotation in positive direction, from fast to slow.
3	0 ... 255	Movement speed, from slow to fast
4	0 ... 255	Master dimmer
5	Stroboscope effect	
	0 ... 9	No function
	10 ... 255	Stroboscope effect from slow to fast

Channel	Value	Function
6	Scenes and banks	
	0 ... 49	No function
	50 ... 59	Intensity Red
	60 ... 69	Intensity Green
	70 ... 79	Intensity Blue
	80 ... 89	Intensity White
	90 ... 99	Intensity Yellow
	100 ... 109	Intensity Cyan
	110 ... 119	Intensity pink
	120 ... 129	all LEDs on white
	130 ... 139	not used
	140 ... 149	Programme 1
	150 ... 159	Programme 2

Channel	Value	Function
	160 ... 169	Programme 3
	170 ... 179	Programme 4
	180 ... 233	not used
	234 ... 236	Reset
	237 ... 249	not used
	250 ... 255	Sound control
7	0 ... 255	Sensitivity of the built-in microphone

7.5 Features in 11-channel DMX mode, BeamBall 100 Quad LED

Channel	Value	Function
1	0 ... 255	Rotation (Pan)
2	Inclination (tilt)	
	0 ... 191	Fixed position
	192 ... 222	Endless rotation in positive direction, from fast to slow.
	223 ... 224	Stop
	225 ... 255	Endless rotation in positive direction, from fast to slow.
3	0 ... 255	Movement speed, from slow to fast
4	0 ... 255	Master dimmer
5	Stroboscope effect	
	0 ... 9	No function
	10 ... 255	Stroboscope effect from slow to fast

Channel	Value	Function
6	0 ... 255	Dimmer red
7	0 ... 255	Dimmer green
8	0 ... 255	Dimmer blue
9	0 ... 255	Dimmer white
10	Scenes and banks	
	0 ... 49	No function
	50 ... 59	Red
	60 ... 69	Green
	70 ... 79	Blue
	80 ... 89	White
	90 ... 99	Yellow
	100 ... 109	Cyan
	110 ... 119	Pink

Channel	Value	Function
	120 ... 129	all LEDs on white
	130 ... 139	not used
	140 ... 149	Programme 1
	150 ... 159	Programme 2
	160 ... 169	Programme 3
	170 ... 179	Programme 4
	180 ... 233	not used
	234 ... 236	Reset
	237 ... 249	not used
	250 ... 255	Sound control
11	0 ... 255	Sensitivity of the built-in microphone

7.6 Features in 15-channel DMX mode, BeamBall 100 Quad LED

Channel	Value	Function
1	0 ... 255	Rotation (Pan)
2	Inclination (tilt)	
	0 ... 191	Fixed position
	192 ... 222	Endless rotation in positive direction, from fast to slow.
	223 ... 224	Stop
	225 ... 255	Endless rotation in positive direction, from fast to slow.
3	0 ... 255	Movement speed, from slow to fast
4	0 ... 255	Master dimmer
5	Stroboscope effect	
	0 ... 9	No function
	10 ... 255	Stroboscope effect from slow to fast

Channel	Value	Function
6	0 ... 255	Dimmer Red, side A (face to the display)
7	0 ... 255	Dimmer Green, side A (face to the display)
8	0 ... 255	Dimmer Blue, side A (face to the display)
9	0 ... 255	Dimmer White, side A (face to the display)
10	0 ... 255	Dimmer Red, side B (face to the terminals)
11	0 ... 255	Dimmer Green, side B (face to the terminals)
12	0 ... 255	Dimmer Blue, side B (face to the terminals)
13	0 ... 255	Dimmer White, side B (face to the terminals)
14	Scenes and banks	
	0 ... 49	No function
	50 ... 59	Red
	60 ... 69	Green
	70 ... 79	Blue

Channel	Value	Function
	80 ... 89	White
	90 ... 99	Yellow
	100 ... 109	Cyan
	110 ... 119	Pink
	120 ... 129	all LEDs on white
	130 ... 139	not used
	140 ... 149	Programme 1
	150 ... 159	Programme 2
	160 ... 169	Programme 3
	170 ... 179	Programme 4
	180 ... 233	not used
	234 ... 236	Reset
	237 ... 249	not used

Channel	Value	Function
	250 ... 255	Sound control
15	0 ... 255	Sensitivity of the built-in microphone

7.7 Features in 49-channel DMX mode, BeamBall 100 Quad LED

Channel	Value	Function
1	0 ... 255	Rotation (Pan)
2	0 ... 255	Fine adjustment rotation (pan)
3	Inclination (tilt)	
	0 ... 191	Fixed position
	192 ... 222	Endless rotation in positive direction, from fast to slow.
	223 ... 224	Stop

Channel	Value	Function
	225 ... 255	Endless rotation in positive direction, from fast to slow.
4	0 ... 255	Fine adjustment inclination (tilt)
5	0 ... 255	Movement speed, from slow to fast
6	0 ... 255	Master dimmer
7	Stroboscope effect	
	0 ... 9	No function
	10 ... 255	Stroboscope effect from slow to fast
8 ... 11	0 ... 255	Dimmer Red, Green, Blue, White, LED 1
12 ... 15	0 ... 255	Dimmer Red, Green, Blue, White, LED 2
16 ... 19	0 ... 255	Dimmer Red, Green, Blue, White, LED 3
20 ... 23	0 ... 255	Dimmer Red, Green, Blue, White, LED 4
24 ... 27	0 ... 255	Dimmer Red, Green, Blue, White, LED 5
28 ... 31	0 ... 255	Dimmer Red, Green, Blue, White, LED 6

Channel	Value	Function
32 ... 35	0 ... 255	Dimmer Red, Green, Blue, White, LED 7
36 ... 39	0 ... 255	Dimmer Red, Green, Blue, White, LED 8
40 ... 43	0 ... 255	Dimmer Red, Green, Blue, White, LED 9
44 ... 47	0 ... 255	Dimmer Red, Green, Blue, White, LED 10
48	Scenes and banks	
	0 ... 49	No function
	50 ... 59	Red
	60 ... 69	Green
	70 ... 79	Blue
	80 ... 89	White
	90 ... 99	Yellow
	100 ... 109	Cyan
	110 ... 119	Pink

Channel	Value	Function
	120 ... 129	all LEDs on white
	130 ... 139	not used
	140 ... 149	Programme 1
	150 ... 159	Programme 2
	160 ... 169	Programme 3
	170 ... 179	Programme 4
	180 ... 233	not used
	234 ... 236	Reset
	237 ... 249	not used
	250 ... 255	Sound control
49	0 ... 255	Sensitivity of the built-in microphone

7.8 Features in 8-channel DMX mode, BeamBall 100 White LED

Channel	Value	Function
1	0 ... 255	Rotation (Pan)
2	Inclination (tilt)	
	0 ... 191	Fixed position
	192 ... 222	Endless rotation in positive direction, from fast to slow.
	223 ... 224	Stop
	225 ... 255	Endless rotation in positive direction, from fast to slow.
3	0 ... 255	Movement speed, from slow to fast
4	Stroboscope effect	
	0 ... 9	No function
	10 ... 255	Stroboscope effect from slow to fast
5	0 ... 255	Dimmer side A (face to the display)

Channel	Value	Function
6	0 ... 255	Dimmer side B (faceto the terminals)
7	Scenes and banks	
	0 ... 49	No function
	50 ... 59	Intensity White
	60 ... 139	not used
	140 ... 149	Programme 1
	150 ... 159	Programme 2
	160 ... 169	Programme 3
	170 ... 179	Programme 4
	180 ... 233	not used
	234 ... 236	Reset
	237 ... 249	not used

Channel	Value	Function
	250 ... 255	Sound control
8	0 ... 255	Sensitivity of the built-in microphone

7.9 Features in 19-channel DMX mode, BeamBall 100 White LED

Channel	Value	Function
1	0 ... 255	Rotation (Pan)
2	0 ... 255	Fine adjustment rotation (pan)
3	Inclination (tilt)	
	0 ... 191	Fixed position
	192 ... 222	Endless rotation in positive direction, from fast to slow.
	223 ... 224	Stop

Channel	Value	Function
	225 ... 255	Endless rotation in positive direction, from fast to slow.
4	0 ... 255	Fine adjustment inclination (tilt)
5	0 ... 255	Stroboscope effect from slow to fast
6	0 ... 255	Master dimmer
7	Stroboscope effect	
	0 ... 9	No function
	10 ... 255	Stroboscope effect from slow to fast
8 ... 17	0 ... 255	Dimmer LED 1 ... LED 10
18	Scenes and banks	
	0 ... 49	No function
	50 ... 59	Intensity White
	60 ... 139	not used
	140 ... 149	Programme 1

Channel	Value	Function
	150 ... 159	Programme 2
	160 ... 169	Programme 3
	170 ... 179	Programme 4
	180 ... 233	not used
	234 ... 236	Reset
	237 ... 249	not used
	250 ... 255	Sound control
19	0 ... 255	Sensitivity of the built-in microphone

8 Technical specifications

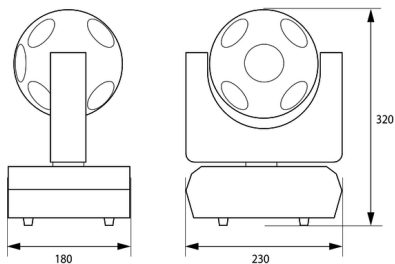

	Beam Ball 100 Quad LED	Beam Ball 100 White LED
Light source	10 × 10 Watt Quad Color RGBW LED	10 × 10 Watt white light-LED, 7000 K
Optical properties	Beam angle	4°...11°
Light output	5500 Lux / 2 m	
Rotation angle (pan), max.	540°	
Inclination angle (tilt), max.	infinite	
Dimmer	0 ... 100 %, linear	
Strobe	1 ... 20 Hz	
Control	Buttons and display on the unit, DMX	
Number of DMX channels	7, 11, 15 or 49	8 or 19
Input connections	Power supply	IEC chassis plug C14

	Beam Ball 100 Quad LED	Beam Ball 100 White LED
	DMX control	XLR chassis socket, 3-pin
Output connections	DMX control	XLR chassis socket, 3-pin
Power consumption	130 W	
Supply voltage	AC 100-240 V ~, 50/60 Hz	
Fuse	5 mm × 20 mm, 2 A, fast blow	
Degree of protection	IP20	
Mounting options	Hanging, standing	
Dimensions (W × H × D)	230 mm × 320 mm × 180 mm	
Weight	5 kg	
Ambient conditions	Temperature range	0 °C...40 °C
	Relative humidity	50 %, non-condensing

Further information

Similar design	Moving Head
DMX control	Yes
Master/Slave	Yes
Remote control	Not possible
Sound control	Yes
Display	Yes

9 Plug and connection assignment

Introduction

This chapter will help you select the right cables and plugs to connect your valuable equipment so that a perfect light experience is guaranteed.

Please take our tips, because especially in 'Sound & Light' caution is indicated: Even if a plug fits into a socket, the result of an incorrect connection may be a destroyed DMX controller, a short circuit or 'just' a not working light show!

DMX connections

The unit offers a 3-pin XLR socket for DMX output and a 3-pin XLR plug for DMX input. Please refer to the drawing and table below for the pin assignment of a suitable XLR plug.



Pin	Configuration
1	Ground, shielding
2	Signal inverted (DMX-, 'cold signal')
3	Signal (DMX+, 'hot signal')

10 Troubleshooting



NOTICE!

Possible data transmission errors

For error-free operation make use of dedicated DMX cables and do not use ordinary microphone cables.

Never connect the DMX input or output to audio devices such as mixers or amplifiers.

In the following we list a few common problems that may occur during operation. We give you some suggestions for easy troubleshooting:

Symptom	Remedy
The unit does not work, no light, the fan does not run	Check the mains connection and the main fuse.
No response to the DMX controller	1. Check the DMX connectors and cables for proper connection.
	2. Check the address settings and the DMX polarity.
	3. Try using another DMX controller.
	4. Check whether the DMX cables run near or parallel to high-voltage cables that may cause damage or interference to a DMX interface circuit.

If the procedures recommended above do not succeed, please contact our Service Center. You can find the contact information at www.thomann.de.

11 Cleaning

Optical lenses

Clean the optical lenses, that are accessible from the outside, regularly in order to optimize the light output. The frequency of cleaning depends on the operating environment: wet, smoky or particularly dirty surroundings can cause more accumulation of dirt on the optics of the device.

- Clean with a soft cloth using our lamp and lens cleaner (item no. 280122).
- Always dry the parts carefully.

Fan grids

The fan grids of the device must be cleaned of any contamination, such as dust, etc. on a regular basis. Before cleaning, switch off the device and disconnect mains-operated devices from the mains. Only use pH-neutral, solvent-free and non-abrasive cleaning agents. Clean the unit with a slightly damp lint-free cloth.

12 Protecting the environment

Disposal of the packaging material



For the transport and protective packaging, environmentally friendly materials have been chosen that can be supplied to normal recycling.

Ensure that plastic bags, packaging, etc. are properly disposed of.

Do not just dispose of these materials with your normal household waste, but make sure that they are collected for recycling. Please follow the notes and markings on the packaging.

Disposal of your old device



This product is subject to the European Waste Electrical and Electronic Equipment Directive (WEEE) in its currently valid version. Do not dispose with your normal household waste.

Dispose of this device through an approved waste disposal firm or through your local waste facility. When discarding the device, comply with the rules and regulations that apply in your country. If in doubt, consult your local waste disposal facility.



